

VAISALA

USER'S GUIDE

Ozone Sounding with Vaisala Radiosonde RS41

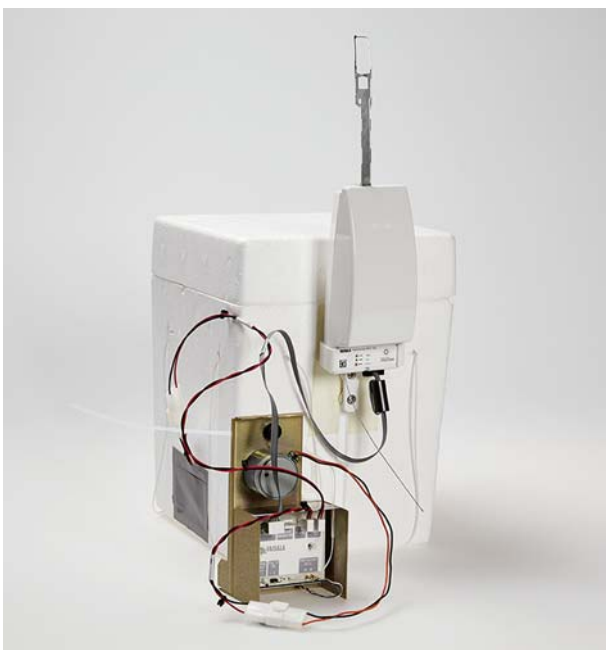

PUBLISHED BY

Vaisala Oyj

Street address: Vanha Nurmijärventie 21, FI-01670 Vantaa,
Finland

Mailing address: P.O.Box 26, FI-00421 Helsinki, Finland

Phone: +358 9 8949 1

Fax: +358 9 8948 2227

Visit our Internet pages at www.vaisala.com/

© Vaisala 2016

No part of this manual may be reproduced, published or publicly displayed in any form or by any means, electronic or mechanical (including photocopying), nor may its contents be modified, translated, adapted, sold or disclosed to a third party without prior written permission of the copyright holder. Translated manuals and translated portions of multilingual documents are based on the original English versions. In ambiguous cases, the English versions are applicable, not the translations.

The contents of this manual are subject to change without prior notice.

Local rules and regulations may vary and they shall take precedence over the information contained in this manual. Vaisala makes no representations on this manual's compliance with the local rules and regulations applicable at any given time, and hereby disclaims any and all responsibilities related thereto.

This manual does not create any legally binding obligations for Vaisala towards customers or end users. All legally binding obligations and agreements are included exclusively in the applicable supply contract or the General Conditions of Sale and General Conditions of Service of Vaisala.

Table of Contents

CHAPTER 1	
GENERAL INFORMATION	9
About This Manual	9
Version Information	11
Related Manuals	11
Documentation Conventions	11
Product-Related Safety Precautions	12
Lithium Battery-Related Precautions	13
Transporting RS41 Radiosondes with Lithium Batteries	13
ESD Protection	15
Recycling	15
Trademarks	15
Product Returns	16
CHAPTER 2	
PRODUCT AND SYSTEM COMPONENT OVERVIEW	17
Introduction to Ozone Sounding	17
Ozone Sensor Unit	18
Ozone Interface Kit RSA411	20
Ozone Interface Board OIF411	21
Radiosonde RS41 Additional Sensor Interface	24
Equipment and Material Needed	25
Vaisala Ozone Sounding Startup Kit	26
Ozonizer/Test Unit TSC-1	27
Ozone Destruction Filter	30
Pump Test Unit	31
Laboratory Ware Set	33
Ozone Chemicals	34
Air Flow Meter	35
Using the Air Flow Meter	35
Other Equipment and Material	38
Balance	38
Thermometer	38
Power Supply	38
Protective Gloves	38
Expendables and Spare Parts	39
CHAPTER 3	
CONSTRUCTING AN OZONE SOUNDING	41
Sounding Preparation Phases and Schedule	41

Preparations 7 to 3 Days Prior to Release	43
Preparation Steps	43
Preparations on the Day of Release	46
Preparation Steps	46
Preparations Just Before Release (2 - 0 Hours)	48
Starting Preparations	49
Attaching Radiosonde Holder to Flight Box	49
Attaching OIF411 to SPC's Ozone Sensor Frame	53
Attaching OIF411 to DMT's Ozone Sensor Frame	56
Connecting Ozone Sensor Wires to OIF411	58
Preparing the Radiosonde and OIF411	61
Connecting Ozone Sensor Pump to OIF411	61
Connecting Ozone Pump Battery to OIF411	62
Connecting Thermistor Cable to Ozone Sensor Pump	63
Connecting Additional Sensor Cable to OIF411	64
Connecting Heating Battery to OIF411 (Optional)	64
Preparing the Radiosonde with Ground Equipment	66
Constructing Sounding Accessories	78
Activating Pump Motor Battery	80
Recording the Surface Ozone	82
Launching the Balloon	82
Recording Post-Launch Data	83
CHAPTER 4	
OZONE CALCULATION	85
Averaging and Eliminating Irrelevant Measuring Results	85
Ozone Partial Pressure Calculation	86
Ozone Sensor Operating Principle	86
Ozone Sensor Reactions	87
Calculation of Local Ozone Values	88
Background Current Correction (IBG)	90
Pumping Time for 100 ml of Air (t)	91
Measured Airflow Temperature (TP)	91
Pump Efficiency Correction (Cef)	91
Additional Correction Factor (Cref)	93
Total Ozone Calculation	93
Total Ozone from Sounding	94
Residual Ozone (Total Ozone after Balloon Burst)	95
Ozone in $\mu\text{g}/\text{m}^3$	96
Accuracy of Ozonesonde Measurement	97
CHAPTER 5	
OZONE INTERFACE BOARD OIF411 DATA	99
Interpreting OIF411 Data	99
Measurement Data	99
ID Data	100
Additional Data	101

CHAPTER 6	
STORAGE AND TRANSPORTATION	103
Storage	103
Transportation	104
CHAPTER 7	
TECHNICAL SUPPORT	105
Product Returns	105
Technical Support	105
APPENDIX A	
DIGICORA MW41 OZONE DATA	107
Calculating Ozone Data in MW41	107
Reporting Ozone Data in MW41	107
Archived Ozone Data in MW41	108
Additional Sensor Data from RS41	109
Additional Sensor Data from RS92	109
Calculated Ozone Data	110
OIF411 or OIF92 Ozone Parameters	110
Ozone Results	112
Raw Ozone Data	113
APPENDIX B	
SAFETY INSTRUCTIONS FOR BALLOON OPERATORS	115
APPENDIX C	
CHECKLIST FOR EQUIPMENT AND SUPPLIES FOR FLIGHT PREPARATIONS	117
APPENDIX D	
PERFORMANCE REVIEW LITERATURE	119

List of Tables

Table 1	Manual Revisions	11
Table 2	Related Manuals	11
Table 3	OIF411 Terminals	22
Table 4	Electrical Interface of RS41 and the Additional Sensor	24
Table 5	Ozone Sounding Startup Kit	26
Table 6	Equipment Required for Ozone Destruction Filter	30
Table 7	Equipment Required for Pump Test Unit	31
Table 8	Laboratory Ware Needed	33
Table 9	Required Ozone Chemicals	34
Table 10	Equipment Required for Air Flow Meter	35
Table 11	Workflow for Ozone Sounding Preparations 45 Minutes Before Launch	48
Table 12	OIF411 Terminals	59
Table 13	Ozone Partial Pressure Correction Factors	92
Table 14	Ozone Partial Pressure Correction Factors	92
Table 15	OIF411 Data Interpretation 1	100
Table 16	OIF411 Data Interpretation 2	101
Table 17	AdditionalSensorData	109
Table 18	RS92SpecialSensorData	109
Table 19	CalculatedOzone	110
Table 20	OIF411Parameters/ OIF92Parameters	110
Table 21	OzoneResults	112
Table 22	RawOzone	113
Table 23	Checklist for Equipment	117
Table 24	Performance Review Literature	119

List of Figures

Figure 1	Lithium Battery Handling Label	14
Figure 2	SPC ECC-6A Ozone Sensor Parts	19
Figure 3	RSA411 Ozone Interface Kit Contents.	20
Figure 4	Ozone Sensor Interface Board OIF411	21
Figure 5	OIF411 Terminals Marked on Sticker	22
Figure 6	OIF411 Dimensions	23
Figure 7	RS41 Additional Sensor Interface	24
Figure 8	Ozonizer/Test Unit TSC-1	27
Figure 9	EC Black Bench O3S Tester Made by EC.	29
Figure 10	EC White Bench O3S Tester Made by Droplet Measurement Technologies.	29
Figure 11	Ozone Destruction Filter	31
Figure 12	Vacuum/Pressure Gauge.	32
Figure 13	Air Flow Rate Measurement.	37
Figure 14	Radiosonde Holder Attachment	50
Figure 15	Radiosonde Holder Measurements (a) and Position (b)	51
Figure 16	Marking the Positions of the Holder Screws	52
Figure 17	Inserting the Dowels	53
Figure 18	Attaching OIF411 to Ozone Sensor	54
Figure 19	Wing Nuts on the Back of OIF411	55
Figure 20	OIF411 Being Attached to the Ozone Sensor Frame	55
Figure 21	OIF411 Wing Nuts Tightened.	56
Figure 22	Droplet Measurements Model Z Sensor	57
Figure 23	Drilling the Ozone Sensor Frame Holes.	57
Figure 24	Ozone Sensor Attached to the DMT Frame with M3 Nuts.	58
Figure 25	OIF411 Terminals Marked on Sticker	59
Figure 26	Connecting Sensor Wires to OIF411	60
Figure 27	Connecting Ozone Sensor Pump Cable	61
Figure 28	Connecting Ozone Sensor Battery Cable	62
Figure 29	SPC ECC-6A with Thermistor Assembled.	63
Figure 30	DMT Model Z with OIF411 Temperature Sensor Assembled	63
Figure 31	Connecting Heating Battery	64
Figure 32	Two-Sided Tape Attached to the Battery	65
Figure 33	Battery Wires Running Between the Ozone Sensor Frame Wall and the Ozone Sensor	65
Figure 34	Ozone Sensor Information	67
Figure 35	Radiosonde Preparation in Progress	67
Figure 36	Waiting for Background Current.	68
Figure 37	Do Not Touch the Radiosonde Sensors.	68
Figure 38	Connecting Radiosonde Cable	69
Figure 39	Checking Radiosonde Interface Connector	69
Figure 40	OIF411 Connected to Radiosonde Interface Connector	70
Figure 41	Do Not Touch the Radiosonde Sensors.	70
Figure 42	Attaching Radiosonde to the Holder	71

Figure 43	Pushing the Holder into Place	72
Figure 44	Radiosonde RS41 Attached to the Holder	72
Figure 45	SPC Ozone Sensor inside the Flight Box.	73
Figure 46	DMT Ozone Sensor inside the Flight Box, Cover About to be Closed	74
Figure 47	Air Outlet Hole and Air Intake Tube Not Taped Over	75
Figure 48	Supported Flight Box String in DMT Ozone Sensor Flight Box	76
Figure 49	Entering Sensor Background Current in MW41	77
Figure 50	Viewing Raw Ozone Data in MW41	77
Figure 51	Assembly of RSU Stabilizer	79
Figure 52	Assembly of Detainer to Unwinder.	79
Figure 53	Unwinder Attached to the Balloon Neck.	80
Figure 54	Taped Flight Box	81
Figure 55	Viewing Raw Ozone Data in MW41	82
Figure 56	Electrochemical Cell Construction	87
Figure 57	Example of an MW41 Ozone Data Report Output	108

CHAPTER 1

GENERAL INFORMATION

This chapter provides general notes for the manual and the product.

About This Manual

This manual provides information on assembling and operating an ozone sounding with RSA411 Ozone Interface Kit, Vaisala Radiosonde RS41, and an ozone sensor.

The manual describes:

- The preparation of the ozone sensor with RSA411 Ozone Interface Kit and Radiosonde RS41. For a list of the ozone sensor manufacturers' manuals, see topic [Related Manuals on page 11](#).
- Sounding preparations before the launch. See Chapter [Constructing an Ozone Sounding on page 41](#).

For information on performing an ozone sounding with sounding software, see the on-line help embedded in MW41 sounding software.

Contents of This Manual

- Chapter 1, [General Information on page 9](#), provides general notes for the manual and the product.
- Chapter 2, [Product and System Component Overview on page 17](#), introduces the product components.
- Chapter 3, [Constructing an Ozone Sounding on page 41](#), describes the sounding preparations with Vaisala Radiosonde RS41, the ozone sensor, and the ground equipment.
- Chapter 4, [Ozone Calculation on page 85](#), describes ozone calculation in detail.
- Chapter 5, [Ozone Interface Board OIF411 Data on page 99](#), explains the data received from Ozone Interface Board OIF411, and how it is interpreted.
- Chapter 6, [Storage and Transportation on page 103](#), provides information for the transport and storage of the product.
- Chapter 7, [Technical Support on page 105](#), provides information on technical support available.
- Appendix A, [DigiCORA MW41 Ozone Data on page 107](#), explains the files containing the ozone-related data in MW41.
- Appendix B, [Safety Instructions for Balloon Operators on page 115](#), lists the preparation steps needed for the ozone sensor, and contains the checklists for the preparations.
- Appendix C, [Checklist for Equipment and Supplies for Flight Preparations on page 117](#), provides a checklist for the equipment needed in an ozone sounding.
- Appendix D, [Performance Review Literature on page 119](#), provides a list of performance review literature.

Version Information

Table 1 Manual Revisions

Manual Code	Description
M211486EN-C	December 2016. Updated information on securing the unwinder attachment for the sounding.
M211486EN-B	January 2016. Updated term ("zero air" changed into "ozone-free air").
M211486EN-A	May 2014. First version.

Related Manuals

Table 2 Related Manuals

Manual Code	Description
M211667EN	Vaisala Radiosonde RS41-SG and RS41-SGP User's Guide
DOC-0336	Droplet Measurement Technologies Model Z ECC Ozonesondes Operator Manual
SPC-6A Manual © SPC	Science Pump Corporation Operator's Manual Model 6A ECC Ozonesonde
SPC TSC-1 © SPC	Science Pump Corporation Operator's Manual Ozonizer/Test Unit Model TSC-1
-	On-line help for Vaisala DigiCORA® Sounding System MW41, available in the sounding software user interface

Documentation Conventions

Throughout the manual, important safety considerations are highlighted as follows:

WARNING

Warning alerts you to a serious hazard. If you do not read and follow instructions very carefully at this point, there is a risk of injury or even death.

CAUTION

Caution warns you of a potential hazard. If you do not read and follow instructions carefully at this point, the product could be damaged or important data could be lost.

NOTE

Note highlights important information on using the product.

Product-Related Safety Precautions

Radiosonde RS41 has been tested for safety and approved as shipped from the factory. Note the following precautions:

WARNING

Conduct soundings in a safe environment and in accordance with all applicable restrictions and regulations.

WARNING

Do not use the radiosonde in an area with power lines or other obstructions overhead. Make sure that you check the area for such obstructions before using the radiosonde.

WARNING

Do not use the radiosonde without consultation and cooperation with local and other applicable aviation authorities.

WARNING

Do not modify the unit in any way, except as instructed in the manual.

WARNING

Do not use the radiosonde for any purpose other than for soundings.

WARNING

The chemicals involved in an ozone sounding can be harmful, and must be handled with proper care. To ensure your working safety, take all the necessary precautions before beginning the preparations for a flight. Read the sensor manuals carefully. Follow the local laboratory work practices, regulations, and waste management guidelines. Use disposable gloves to avoid dust and other contaminants. The gloves must be lint-free and made of artificial fabric or plastic. RSA411 Ozone Interface Kit does not include gloves.

WARNING

Vaisala recommends the use of parachute even if it is not required by applicable restrictions.

Lithium Battery-Related Precautions

CAUTION

Do not place the lithium battery in fire or apply heat to the battery.

Do not pierce the battery with nails, strike the battery with a hammer, step on the battery, or otherwise damage the outer casing.

Do not subject the battery pack to strong impacts or shocks.

Do not expose the battery to water or salt water, or allow the battery to get wet.

Do not disassemble or modify the battery. The battery contains safety and protection devices which, if damaged, may cause the battery to generate heat, rupture or ignite.

Do not leave the battery in direct sunlight, or use or store the battery inside cars in hot weather. Doing so may cause the battery to generate heat, rupture, or ignite. Using the battery in this manner may also result in shortened life expectancy and loss of performance.

Never short circuit, reverse polarity, disassemble, damage, or heat the battery over 100 °C (212 °F). If an exposed lithium battery does not start on fire, it will burn even more violently if it comes into contact with water or even moisture in the air.

DO NOT THROW WATER ON A BURNING BATTERY. A fire extinguisher must be used.

Transporting RS41 Radiosondes with Lithium Batteries

RS41 radiosondes with lithium batteries are classified as:

- UN 3091 Lithium metal batteries contained in equipment

Consignments must be packed, labeled, and documented according to the IATA packing instructions.

When transporting the radiosondes with lithium batteries, take the following requirements into account:

- The package must display a lithium battery handling label, see [Figure 1 on page 14](#) for an example. The original radiosonde

shipping package must be used for transport, and it already has the lithium battery handling label.

- The consignment must include a document indicating the lithium content, describing proper handling and procedures for damaged packages, and a telephone number for additional information. The original radiosonde consignment includes a SHIPPER'S DECLARATION FOR ARTICLES NOT REGULATED AS DANGEROUS GOODS, which should be reused for this purpose after updating the appropriate information.



Figure 1 **Lithium Battery Handling Label**

NOTE

If the lithium battery is faulty, do not transport it.

ESD Protection

Electrostatic Discharge (ESD) can cause immediate or latent damage to electronic circuits. Vaisala products are adequately protected against ESD for their intended use. However, it is possible to damage the product by delivering electrostatic discharges when touching, removing, or inserting any objects inside the equipment housing.

To make sure you are not delivering high static voltages yourself:

- Handle ESD sensitive components on a properly grounded and protected ESD workbench. When this is not possible, ground yourself to the equipment chassis before touching the boards. Ground yourself with a wrist strap and a resistive connection cord.

CAUTION

Touch a conductive part of the equipment chassis with your other hand before touching the boards.

- Always hold the boards by the edges and avoid touching the component contacts.

Recycling



Recycle all applicable material.



Dispose of batteries and the unit according to statutory regulations. Do not dispose of with regular household refuse.

Trademarks

DigiCORA® is a registered trademark of Vaisala Oyj.

Product Returns

If the product must be returned for service, see www.vaisala.com/returns.

For contact information of Vaisala Service Centers, see www.vaisala.com/servicecenters.

CHAPTER 2

PRODUCT AND SYSTEM COMPONENT OVERVIEW

This chapter introduces the product and system components in more detail.

Introduction to Ozone Sounding

An ozone sounding with RS41 consists of an ozone sensor unit, RSA411 Ozone Interface Kit, and RS41 radiosonde. These are described in the sections below. Other equipment needed is also explained. For detailed information on the radiosonde, see Vaisala Radiosonde RS41-SG and RS41-SGP User's Guide.

In an ozone sounding, the radiosonde is attached to a styrofoam flight box which contains the ozone sensor unit and the interface card. The battery for powering the ozone pump is placed in a compartment on the side of the box. For information on performing an ozone sounding with Vaisala Radiosonde RS41, see also the MW41 on-line help, embedded in the sounding system software.

Ozone Sensor Unit

The ozone sensor unit is either of the following:

- Science Pump Corporation (SPC) Model ECC-6A ozone sensor
- Droplet Measurement Technologies (DMT) Model Z ozone sensor

The sensors are based on chemical reaction cells. The type of the sensors is electrochemical concentration cell (ECC). Air is sampled flow (by using a pump) and it goes to a reaction cell, in which the sampled ozone reacts in a solution, and the current developed in the reaction is detected and measured with an ozone interface. The ozone sensor units are thoroughly discussed in the sensor manufacturers' manuals (see section [Related Manuals on page 11](#)) and Performance Review Literature listed in Appendix D [Performance Review Literature on page 119](#).

The main parts of an SPC ECC-6A ozone sensor are seen in [Figure 2 on page 19](#). Model Z ozone sensor is similar to the SPC sensor. Refer to the sensor manufacturer's manuals for more detailed information.

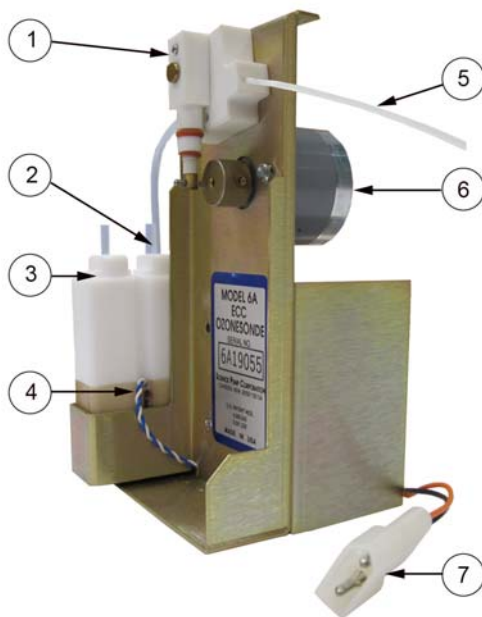

Figure 2 SPC ECC-6A Ozone Sensor Parts

The following numbers refer to [Figure 2 on page 19](#):

- 1 = Gas sampling pump
- 2 = Ozone sensor cathode
- 3 = Ozone sensor anode
- 4 = Wires for interface
- 5 = Air intake tube
- 6 = Motor
- 7 = Connector for pump battery

Ozone Interface Kit RSA411

The RSA411 kit is used with Radiosonde RS41 and Science Pump Corporation's (SPC) ECC type sensors Model ECC6A, or Droplet Measurement Technologies (DMT) Model Z. The kit contains the items listed below. The numbers refer to [Figure 3 on page 20](#).

1. Radiosonde holder with three plastic dowels and three screws for attaching the holder to the flight box wall. The plastic bag also contains two M3 nuts for attaching Ozone Interface Board OIF411 to DMT's ozone sensor frame. The M3 nuts are an alternative for the wing nuts included in OIF411.
2. Four cables: RS41-OIF411 cable CBL210224, OIF411 power cable CBL210225, OIF411 pump cable CBL210282, and OIF411 heater cable CBL210295.
3. Vaisala OIF411 with temperature sensor cable. The OIF411 temperature sensor is an NTC thermistor. OIF411 includes wing nuts for attaching it to SPC's ozone sensor frame.
4. RSU stabilizer, used with parachute or radar reflector.
5. Detainer for the radiosonde unwinder.

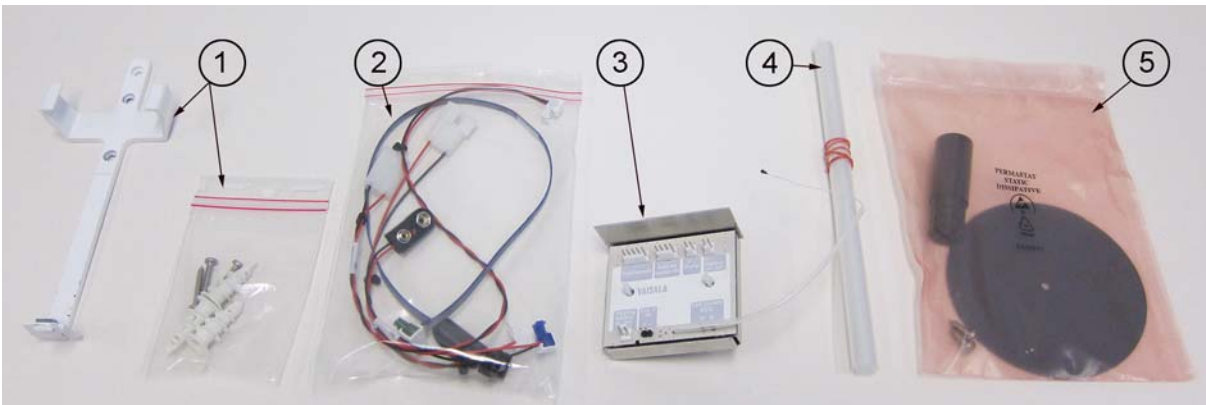

Figure 3 RSA411 Ozone Interface Kit Contents

Ozone Interface Board OIF411

Ozone Interface Board OIF411 has four dedicated channels (ozone sensor current and temperature, battery voltage, and ozone pump current), and an additional voltage measurement channel for other purposes.



Figure 4 Ozone Sensor Interface Board OIF411

The terminals on OIF411 are marked with a sticker attached on the card. See [Figure 5 on page 22](#) for details. The numbers in the figure refer to [Table 3 on page 22](#).

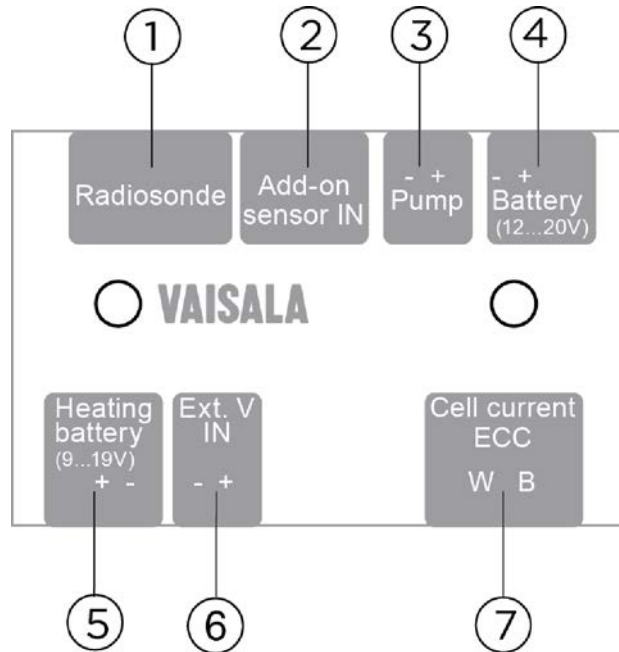

Figure 5 OIF411 Terminals Marked on Sticker

Table 3 OIF411 Terminals

Number	Connection	Cable Code
1	Radiosonde interface	CBL210224
2	Add-on sensor IN for optional XDATA sensors	
3	Pump motor	CBL210282
4	Ozone pump motor battery	CBL210225
5	Heating battery	CBL210295
6	Extra terminal	
7	SPC sensor W = white cable B = blue cable	

[Figure 6 on page 23](#) shows the dimensions of OIF411. The dimensions are in millimeters.

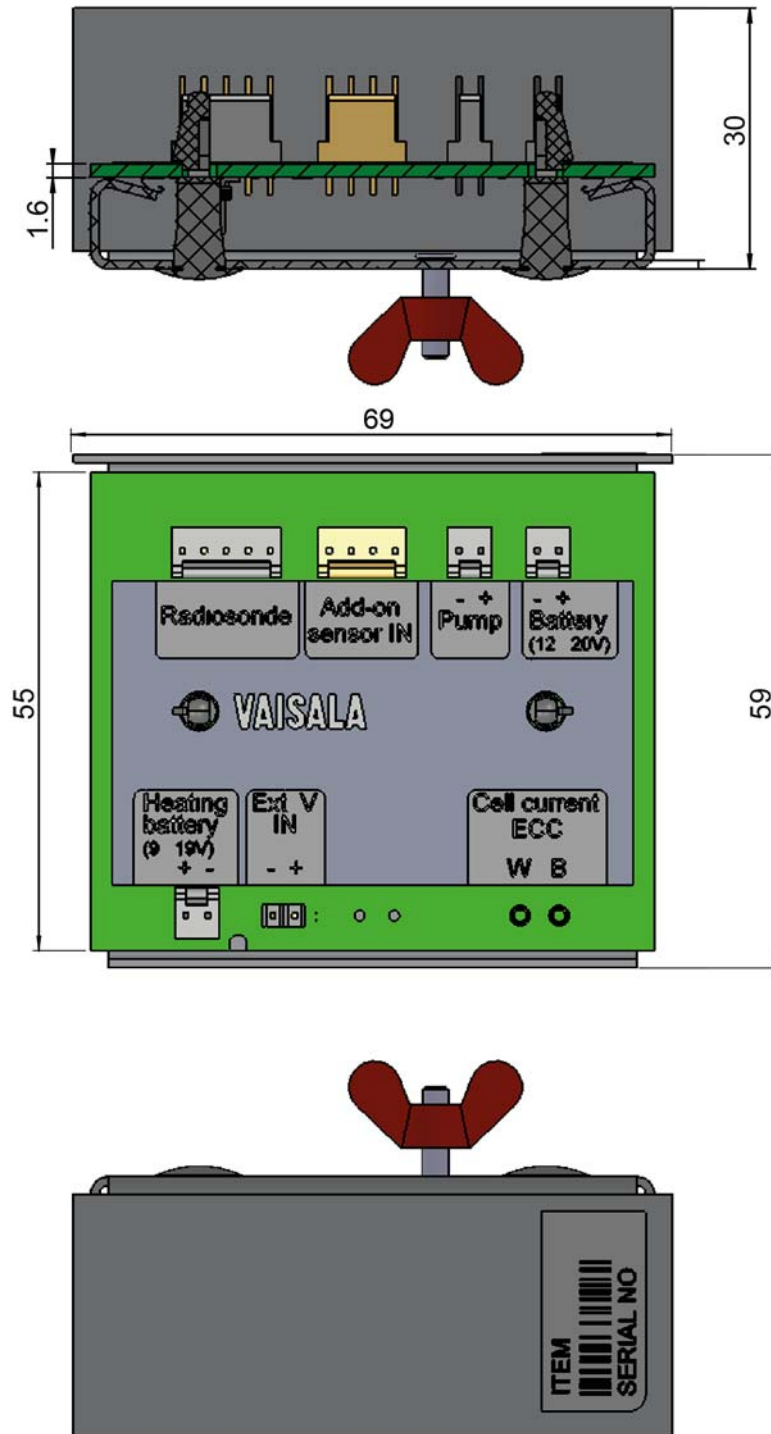

Figure 6 OIF411 Dimensions

Radiosonde RS41 Additional Sensor Interface

Figure 7 on page 24 shows details of the radiosonde additional interface connector. See also Table 4 on page 24 for details on the RS41 electrical interface and the additional sensor.

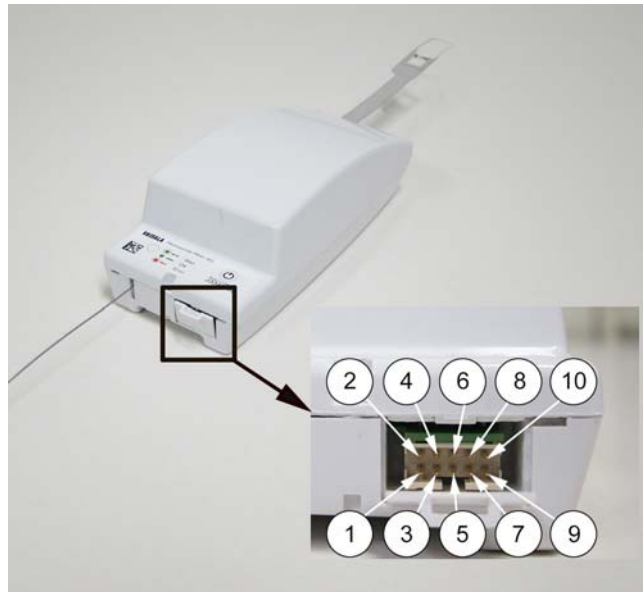

Figure 7 RS41 Additional Sensor Interface

Table 4 Electrical Interface of RS41 and the Additional Sensor

Radiosonde				Additional Sensor	
Pin	Name	I/O	Function	Pin	Name
1	GND	-	Ground		Common
2	RxD	I	Serial data from the additional sensor		Instrument Serial OUT
3	TxD	O	Serial data to the additional sensor		Instrument Serial IN
4 ... 10	Reserved		For Vaisala use only		Do not connect

Equipment and Material Needed

Several items are needed to prepare the ozone sensor and the radiosonde for a flight. The items listed below are included in the Vaisala Ozone Sounding Startup Kit and they are explained in more detail in the sections below:

- Ozonizer/Test Unit TSC-1 (or similar, from other manufacturers)
- Ozone destruction filter
- Pump test unit
- Laboratory ware set
- Ozone chemicals
- Air flow meter

These items are valid when using the SPC ECC-6A ozone sensor or Droplet Measurement Technologies Model Z ozone sensor. Some sensor manufacturers also have their own startup kits. Note that these kits may not necessarily include all the required items for conducting an ozone sounding. For more details, refer to the sensor manufacturers' manuals.

Vaisala Ozone Sounding Startup Kit

Vaisala part number 25820OS.

Vaisala Ozone Sounding Startup Kit is used when preparing a new ozone sounding site. The kit includes materials and equipment for the sounding preparations. A list of the items and their part numbers are provided in [Table 5 on page 26](#). More detailed information is given in the sections below.

Table 5 Ozone Sounding Startup Kit

Pieces	Item	Vaisala Part Number
1	Ozonizer/Test Unit TSC-1	12768
1	Ozone destruction filter	13197OS
1	Pump test unit	12785OS
1	Set of laboratory ware	13198OS
1	Ozone chemicals	13199OS
1	Air flow meter	1319OS
1	Balance	12771
1	Power supply	12767
1	Ozone documentation (includes several manuals)	

Also note the following points:

- The preparation startup kit delivered by SPC (see Operator's Manual for Model 6A-ECC Ozonesonde) differs from the Vaisala startup kit.
- The preparation startup kit delivered by Droplet Measurement Technologies (Operator Manual for Corporation Model Z Ozonesonde, or product brochure) differs from the Vaisala startup kit.
- Triple-distilled water and some other chemicals are not delivered, as they are easily available on the local sites.
- Documentation contains several manuals. Refer to section [Related Manuals on page 11](#) for further details.
- Instructions for using the sounding software are needed to conduct a successful sounding. In addition to the instructions in this manual, MW41 sounding software contains an embedded on-line help with instructions for performing an ozone sounding.
- The Ozonizer/Test Unit TSC-1 is traditionally used for ozone sensor preparation. However, these days it is possible to substitute

it with different models that have a digital ampere meter. A newer digital model is available from DMT (see [Figure 10 on page 29](#) in section [Ozonizer/Test Unit TSC-1 on page 27](#)).

Ozonizer/Test Unit TSC-1

This topic and [Figure 8 on page 27](#) present the Science Pump Corporation Model TSC-1 Ozonizer/Test Unit in more detail. Other options are also available, see [Figure 9 on page 29](#) and [Figure 10 on page 29](#).

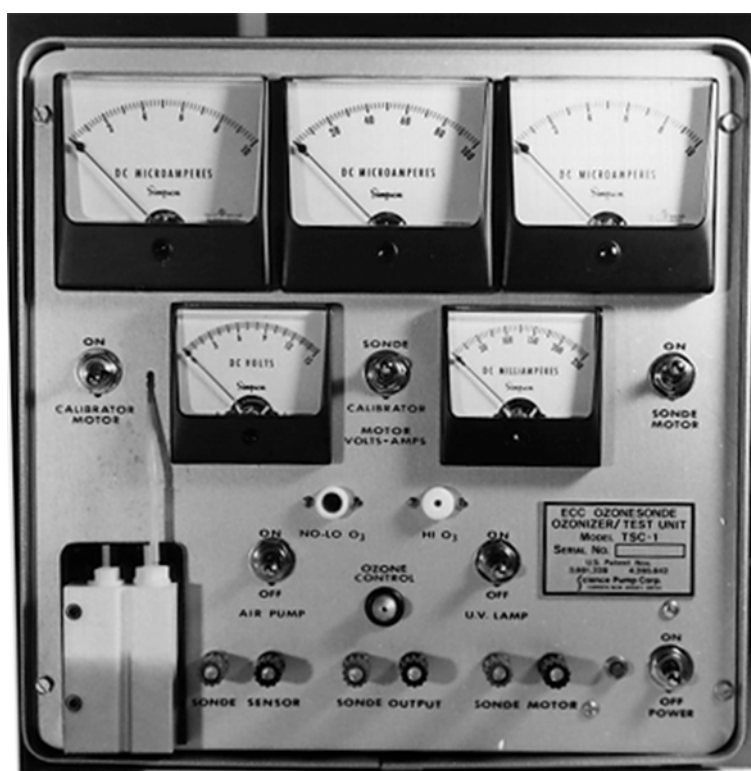

Figure 8 Ozonizer/Test Unit TSC-1

NOTE

Vaisala recommends adding a digital ampere meter with a minimum resolution of 0.01 μA beside Ozonizer TSC-1, and checking the current from the digital ampere meter instead of the analog meter on TSC-1.

The Science Pump Corporation Model TSC-1 Ozonizer/Test Unit (or a similar equipment, see [Figure 9 on page 29](#) and [Figure 10 on page 29](#)) is a necessary basic equipment for the preparations.

The TSC-1 Ozonizer/Test Unit model has been designed for conditioning ECC ozonesondes with the ozone, and for checking the radiosonde's performance prior to balloon release.

The Ozonizer/Test Unit and its operation are described in more detail in the SPC Operator's Manual for Model 6A-ECC Ozonesonde and in the SPC Operator's Manual for Model TSC-1 Ozonizer/Test Unit. See [Table 1 on page 11](#) for a list of related manuals.

The following spare parts are available for TSC-1:

- Calibrator ECC ozone sensor, OTU-15. Vaisala part number 18955.
- Internal ozone filter, OTU-17. Vaisala part number 18960.
- Other spare parts mentioned in the TSC-1 manual are also available.

NOTE

For background current measurement, the ampere meter resolution must be 0.01 μA . This is difficult to achieve with an analog ampere meter, thus the GAW report 201 recommends the use of a digital model.



Figure 9 EC Black Bench O3S Tester Made by EC



Figure 10 EC White Bench O3S Tester Made by Droplet Measurement Technologies

Ozone Destruction Filter

The ozone destruction filter eliminates ozone generated during testing. [Table 6 on page 30](#) lists the parts required for the ozone destruction filter. However, the ASOPOS panel (Assessment of Standard Operating Procedures for Ozonesondes) recommends the use of purified, ozone-free air instead of the destruction filter. Refer to the GAW report 201 for more information. See Appendix D [Performance Review Literature on page 119](#).

Table 6 Equipment Required for Ozone Destruction Filter

Item Required	Vaisala Part Number
Particle and ozone filter: Mine Safety Appliances (MSA) Company. Delivered by MSA as a single cartridge (part number 815185).	234561 (1 pc)
Funnel, 75 mm in diameter, tube diameter 8 mm, glass	12725
Connector tube 1: soft silicon tube approximately 5 cm long, inner diameter 6 mm, outer diameter 10 mm	12642OS (set of tubes)
Connector tube 2: soft vinyl tube approximately 60 cm long, I.D. 1/8" (3.2 mm), O.D. 1/4" (6.4 mm)	12642OS (set of tubes)
Connector tube 3: soft silicon tube approximately 2 cm long, inner diameter 2 mm, outer diameter 4 mm	12642OS (set of tubes)
Connector tube 4: Cut a piece of tubing from the ECC sensor air intake tube (2 cm), or order separately.	17348S (by the meter) or SPC spare part No. OTU-19
Electrical tape (Nitto 15)	4103

Assemble the ozone destruction filter components as shown in [Figure 11 on page 31](#).

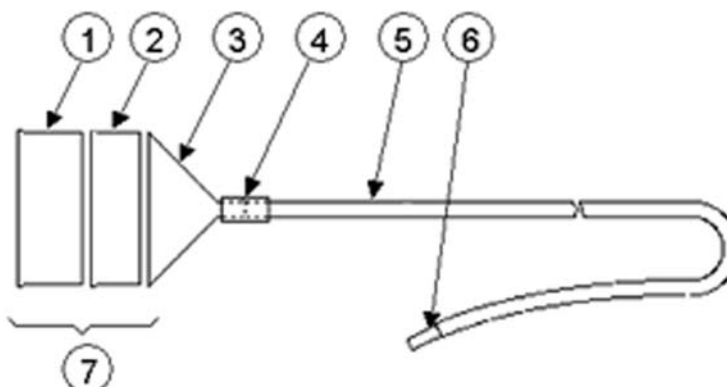

Figure 11 Ozone Destruction Filter

The following numbers refer to [Figure 11 on page 31](#):

- 1 = Catalyst
- 2 = Ultra fiber
- 3 = Funnel
- 4 = Connector tube 1
- 5 = Connector tube 2
- 6 = Connector tube 3
- 7 = Tape 1, 2, and 3 together with electrical tape.

Pump Test Unit

[Table 7 on page 31](#) lists the equipment needed for the pump test unit.

Table 7 Equipment Required for Pump Test Unit

Item Required	Vaisala Part Number
Vacuum/pressure gauge and connection screw. Range -1 ... 1.5 Bar, division 0.05 Bar. Includes connection parts for measurement gauge to tubing.	15240
Locking nut	
Connector tube 1: soft vinyl tube approximately 60 cm long, I.D. 1/8" (3.2 mm), O.D. 1/4" (6.4 mm)	12642OS (set of tubes)
Connector tube 2: soft silicon tube approximately 2 cm long, inner diameter 2 mm, outer diameter 4 mm	12642OS (set of tubes)

Table 7 Equipment Required for Pump Test Unit (Continued)

Item Required	Vaisala Part Number
Connection tube 3: cut a piece of tubing from EEC sensor air inlet tubes to a length of approximately 3 cm, or order separately.	17348S (by the meter) or SPC spare part No. OTU-19

Set up the vacuum/pressure gauge as shown in [Figure 12 on page 32](#).

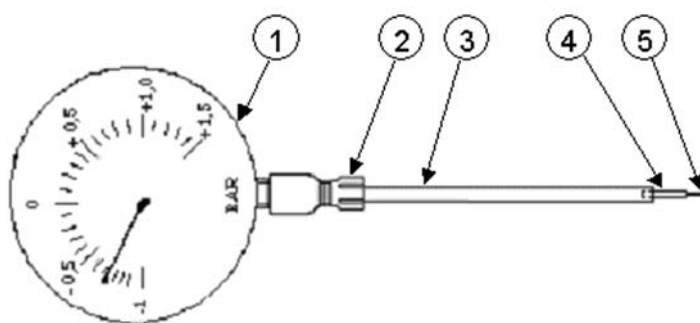

Figure 12 Vacuum/Pressure Gauge

The following numbers refer to [Figure 12 on page 32](#):

- 1 = Gauge and connection screw
- 2 = Locking nut
- 3 = Connector tube 1
- 4 = Connector tube 2
- 5 = Connector tube 3

Set up the pump unit following the steps below:

1. Insert connector tube 1 into the locking nut (see number 3 in [Figure 12 on page 32](#)).
2. Push the tube over the tip of the connection screw on the gauge (number 1).
3. Gently tighten the locking nut over the connector tube onto the gauge (number 2).

NOTE

Be careful when attaching connector tube 1 to the connection screw tip. Be sure to tighten the locking nut gently to avoid damaging or tearing the connection tube. The condition of the connection tube can be checked by opening the locking nut.

4. Insert connector tube 2 (number 4) into connector tube 1 (number 3) by at least 5 mm.
5. Finally, insert the connector tube 3 (number 5) into connector tube 2 (number 4) by at least 1 cm.

Laboratory Ware Set

Bottles and glassware are needed, for instance, for preparing and storing sensing solutions, and for sensor cleaning. The set presented in [Table 8 on page 33](#) is useful and can easily be obtained from any laboratory ware dealer. The set can also be ordered from Vaisala by referring to the part numbers listed in the table.

Table 8 Laboratory Ware Needed

Item	Pieces	Vaisala Part Number
Beakers (Pyrex glass)	1 pc, volume 250 ml (subdivision 50 ml)	12721
	1 pc, volume 50 ml	12720
Cylinder (Pyrex glass)	1 pc, volume 100 ml (subdivision 1 ml)	12722
Volumetric flasks with stoppers (Pyrex glass)	1 pc, volume 1000 ml	12724
	1 pc, volume 500 ml	214857
	1 pc, volume 100 ml	12723
Bottles with stoppers (preferably colored glass)	2 pcs, volume 1000 ml	12738 + 12740
	2 pcs, volume 100 ml	12739 + 12740
Funnels	2 pcs, mouth diameter 75 mm, pipe 10 mm, for liquids, glass	12725
	1 pc, mouth diameter 65 mm, pipe 10 mm, for powder, polypropylene	12726
Spatulas	3 pcs, polypropylene or steel	12729
Basins (polypropylene or glass)	2 pcs, for powder weighing	12727

Table 8 Laboratory Ware Needed (Continued)

Item	Pieces	Vaisala Part Number
Syringes with needle	Disposable; total volume 3 ml, division. 0.1 ml (at least 0.5 ml). Plastic (Teflon) 2 pcs, Syringe 2 pcs, Syringe needle	12736 12737
Thermometer	1 pc, for room temperatures	HST12

Ozone Chemicals

The chemicals used must be very pure, at least of Pro Analysis quality.

Table 9 Required Ozone Chemicals

Chemical Required	Amount	Vaisala Part Number
KI	1 kg	12743
KBr	0.5 kg	12744
NaH ₂ PO ₄ ·H ₂ O	0.5 kg	12741
Na ₂ HPO ₄ ·12H ₂ O (or Na ₂ HPO ₄ ·7H ₂ O)	0.5 kg	12742
Methanol (CH ₃ OH)		-
Glycerol		-
Acetone		-

Air Flow Meter

Table 10 on page 35 lists the equipment required for the Air Flow Meter. Section [Using the Air Flow Meter on page 35](#) explains how the air flow meter is used in ozone sounding preparations. [Figure 13 on page 37](#) shows an example of an air flow meter.

Table 10 Equipment Required for Air Flow Meter

Item Required	Vaisala Part Number
Air flow meter tube. Burette with filling tube, capacity 100 ml	12733
Rubber bulb, capacity approximately from 50 to 80 ml	12734
Burette stand with two bossheads and two clamps	12730 (stand), 12732 (bosshead), 12728 (clamp)
Stop-watch, accuracy at least 0.1 s	12784
Connector tube 1: soft silicon tube approximately 5 cm long, inner diameter 6 mm, outer diameter 10 mm	12642OS (set of tubes)
Connector tube 2: soft vinyl tube approximately 60 cm long, I.D. 1/8" (3.2 mm), O.D. 1/4" (6.4 mm)	12642OS (set of tubes)
Connector tube 3: soft silicon tube approximately 2 cm long, inner diameter 2 mm, outer diameter 4 mm	12642OS (set of tubes)
Dishwashing liquid: Add about one teaspoon of dishwashing liquid and one teaspoon of glycerol to 1 dl of water.	

Using the Air Flow Meter

This procedure is meant to be carried out with no remarkable breaks (that is, breaks lasting over two hours).

NOTE

To avoid contamination, note the following precautions:
 Work in a clean environment with clean hands.
 Never operate the pump without the ozone destruction filter or purified air.
 Do not use a sensor loaded with solutions if the sensor is not connected to a powered interface (or if the anode and cathode wires are connected).

Arrange the air flow meter as shown in [Figure 13 on page 37](#). The procedure for air flow measurement is described below. The numbers within brackets refer to the items in [Figure 13 on page 37](#):

1. Fill the rubber bulb (4) and the flow meter tube with soap solution (8) almost up to the filling tube of the flow meter tube.
2. Connect the air flow meter to the sensor cathode air exhaust tube. This is done by slipping the connector tube 3 (9) over the short Teflon tube protruding from the top plug of the sensor cathode chamber.
3. With the radiosonde air pump operating, squeeze the rubber bulb (4) slightly to cause several soap bubbles to rise up the flow meter tube. Repeat the process several times, until the bubbles reach the top of the tube without breaking.
4. Now form only one bubble, and use a stop-watch to determine the time (t) required for the bubble to rise from 0 to 100 ml up the flow meter tube (5). Repeat the measurement three times to obtain a mean value.

NOTE

When the air flow is measured, make sure the sensor is charged with the sensing solution.

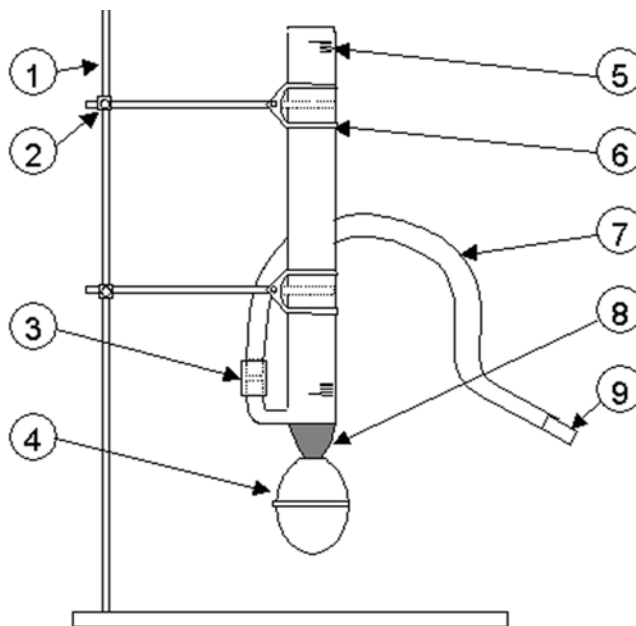

Figure 13 Air Flow Rate Measurement

The following numbers refer to [Figure 13 on page 37](#):

- 1 = Stand
- 2 = Bosshead
- 3 = Connector tube 1
- 4 = Rubber bulb
- 5 = Flow meter tube
- 6 = Clamp
- 7 = Connector tube 2
- 8 = Dishwashing liquid
- 9 = Connector tube 3

Other Equipment and Material

Balance

The balance must fulfill the following requirements:

- Measurement range must be from 0 to 500 g.
- Accuracy required is 0.01 g.

Thermometer

A thermometer is needed for measuring air temperature. It can be a mercury thermometer or an electrical thermometer.

The thermometer must be capable of measuring normal room temperature, a suitable measurement range is between -2 and +50 °C. The recommended thermometer subdivision is 0.1 or 0.2 °C.

Power Supply

A power supply rated at 5 to 18 VDC, 300 mA is required for the ozone pump motor. Refer to the manufacturers' manuals for details.

Protective Gloves

Use disposable gloves to avoid dust and other contaminants. The gloves must be lint-free and made of artificial fabric or plastic. Note that RSA411 Ozone Interface Kit does not include gloves.

Expendables and Spare Parts

After establishing an ozone sounding site, check the availability of expendables and spare parts. Making a list of these items is recommendable. A large variety of spare parts is available from Vaisala.

The list of expendables includes at least:

- Radiosondes, interfaces
- Sounding accessories (for example, balloons)
- Ozone solution chemicals
- Syringes, needles
- Protective gloves
- Triple-distilled or ion-changed water

See also Appendix E [Checklist for Equipment and Supplies for Flight Preparations on page 117](#).

CHAPTER 3

CONSTRUCTING AN OZONE SOUNDING

This chapter describes how to construct an ozone sounding.

WARNING

The chemicals involved in an ozone sounding can be harmful, and must be handled with proper care. To ensure your working safety, take all the necessary precautions before beginning the preparations for a flight. Read the sensor manuals carefully. Follow the local laboratory work practices, regulations, and waste management guidelines. Use disposable gloves to avoid dust and other contaminants. The gloves must be lint-free and made of artificial fabric or plastic. RSA411 Ozone Interface Kit does not include gloves.

Sounding Preparation Phases and Schedule

Perform the preparations preferably at temperatures between +20 and +30 °C.

Preparing an ozone sounding consists of the following steps. See the sections below for more information.

- [Preparations 7 to 3 Days Prior to Release on page 43.](#)
- [Preparations on the Day of Release on page 46.](#)
- [Preparations Just Before Release \(2 - 0 Hours\) on page 48.](#)

NOTE

The ASOPOS panel recommends using the following as sensing solutions:

SPC6A: 1.0%, KI, full buffer (STT1.0)

DTM: 0.5% KI, half buffer (SST0.5)

The recommendation is only meant for new ozone sounding stations. The existing stations that perform long-term measurements must not change their sensing solution type or ECC type.

The ASOPOS panel recommends recording three different background currents:

- I_{B0} : after 10 minutes of ozone-free air before exposure of ozone.
- I_{B1} : after 10 minutes of ozone-free air after exposure of ozone (5 μ A ozone equivalent of 170 - 180 ppbv).
- I_{B2} : at launch site after 10 minutes of ozone-free air.

NOTE

I_{B2} equals to Vaisala $I_{BG} = I_0$, used in Vaisala scripts.

Preparations 7 to 3 Days Prior to Release

This phase consists of checking the overall performance of the ozone sensor, and charging the sensor with the sensing solution. A Model TSC-1 Ozonizer/Test Unit is used to check the overall sensor performance.

The purpose of these preparations is to make sure that the ozone sensor functions properly and can be used in an ozone sounding.

The limit values mentioned here are valid only for SPC ECC-6A ozone sensor. For other ozone sensors, create and use a modified checklist.

WARNING

The chemicals involved in an ozone sounding can be harmful, and must be handled with proper care. To ensure your working safety, take all the necessary precautions before beginning the preparations for a flight. Read the sensor manuals carefully. Follow the local laboratory work practices, regulations, and waste management guidelines. Use disposable gloves to avoid dust and other contaminants. The gloves must be lint-free and made of artificial fabric or plastic. RSA411 Ozone Interface Kit does not include gloves.

NOTE

Make sure to perform the initial preparations early enough, from 1 week to 3 days before the ozone sounding release. This must be done to attain a low sensor background current and a fast sensor response to ozone.

Preparation Steps

To enable smooth operation, place all the necessary parts on a table, but leave some free space in front of the ozonizer, if necessary.

1. Write down the following information:
Date: _____ Station: _____ Operator: _____
2. Check the label on the flight box and record the information here.
Ozone sensor number:
Manufacturer:
Date of manufacture:
Pump pressure: _____ in Hg

Pump voltage: _____ V DC

Pump current: _____ mA

Flow rate: _____ s/100 ml

3. Connect the ozone sensor to the ozonizer (motor, output, sensor leads).

- a. Turn on the ozonizer.

- b. Record I_{B0} before applying any ozone to the sensor:

I_{B0} _____ μA

4. Condition the pump and the dry sensor with HI O₃ for 30 minutes.
5. After 10 minutes of HI O₃, check the following values from the ozonizer:

	Measured	Limit values
Pump voltage	_____ V	12 ... 13 V
Pump current	_____ mA	SPC: < 115 mA; DTM: <100 mA
Head pressure	_____ Pa	> 670 hPa app. 20 in Hg
Vacuum (this is a minus value)	_____ Pa	> 670 hPa app. 20 in Hg

(Normal head pressure and vacuum values are 700 ... 900 hPa)

6. Turn off HI O₃. Run NO O₃ for 5 minutes.
7. Next, you must charge sensor cathode and anode. Use a different syringe for cathode and anode.

Charge sensor **cathode** with solution 3.0 cm³ and wait 2 minutes.

Charge sensor **anode** with solution 1.5 cm³.

8. The current starts to decrease. Sensor background current after 10 minutes (typically the value is under 1.5 μA) on NO O₃:

_____ μA

9. Run on moderate ozone (about 5 μA) for 10 minutes.

10. Check the sensor response to LO O₃. It should be about 5 μA.
11. Run on NO O₃ for 10 minutes. Record the background current:
I_{B1}_____μA
12. Switch everything off and short-circuit the ozone sensor wires.
13. Put the ozone sensor back to the flight box and store it in a dark, clean-air environment at a temperature of 20 ... 25 °C until it is used.

After these preparations, a sensor cleaning process takes place, whereby both half cells (anode and cathode) and ionbridge get in balance.

Preparations on the Day of Release

Preparation Steps

NOTE	The CAL measurements are applicable when SPC's TSC-1 Ozonizer/Test unit is used. They can be ignored with DMT's ozonizer.
-------------	---

1. Write down the following information:
Date: _____ Station: _____ Operator: _____
Ozonesonde number: _____
Manufacturer: _____
Date of manufacture: _____
2. Run the ozone sensor motor for 5 minutes on NO O₃ (optional).
3. Change cathode solution in SONDE (S) and CAL (calibrator, C; with TSC-1 only) sensors:
S: _____ ml
C: _____ ml
The ASOPOS panel recommends the following:
 - a. Dump both solutions carefully (cathode and anode).
 - b. Recharge cathode cell with 3.0 cm³ cathode solution.
 - c. Recharge anode cell with 1.5 cm³ anode solution.
4. Condition SONDE (S) and CAL (C; with TSC-1 only.) NO O₃ for 10 minutes.
5. Sensor's background currents (< 0.2 μA. ASOPOS recommendation 0.05 μA):
 $i_{bc} = \text{_____ } \mu\text{A}$
 $i_{bs} = \text{_____ } \mu\text{A}$ (<0.05 μA; defined as I_{B0} by ASOPOS)

6. Condition SONDE and CAL (with TSC-1 only) sensors with $5 \pm 0.2 \mu\text{A O}_3$ for 5 minutes.

Measure:

SONDE sensor air flow rate:

$$t_s = \text{_____, _____, _____, _____, _____ s}$$

CAL sensor air flow rate:

$$t_c = \text{_____, _____, _____, _____, _____ s}$$

$$T_{\text{room}} = \text{_____ } ^\circ\text{C}; P_{\text{room}} = \text{_____ hPa}; RH_{\text{room}} = \text{_____ } \%$$

7. After 5 minutes of conditioning with about $5 \mu\text{A O}_3$:

$$i_c = \mu\text{A _____ } i_s = \mu\text{A _____}$$

With NO O_3 , check the sensor response test, 30 seconds:

$$i_{0.51c} = \text{_____ } \mu\text{A } i_{0.5s} = \mu\text{A _____ } 0.5 \text{ minute}$$

$$i_{1c} = \text{_____ } \mu\text{A } i_{1s} = \mu\text{A _____ } 1 \text{ minute}$$

$$i_{2c} = \text{_____ } \mu\text{A } i_{2s} = \mu\text{A _____ } 3 \text{ minutes}$$

$$i_{3c} = \text{_____ } \mu\text{A } i_{3s} = \mu\text{A _____ } 5 \text{ minutes}$$

$$i_{10c} = \text{_____ } \mu\text{A } i_{10s} = \mu\text{A _____ } 10 \text{ minutes (equals to } I_{B1})$$

Record cell current at $t = 0, 0.5, 1, 3, 5,$ and 10 minutes (as recommended by ASOPOS $i_{10s} = I_{B1}$ background current).

Computed for calibration acceptance check out:

$(i_c - i_{bc}) t_c = \text{_____ } (i_s - i_{bs}) t_s = \text{_____}$ (agree to within 5%. If necessary, take corrective action to get the desired result. See Science Pump Corporation's Operator's Manual for further instructions.)

$$i_{1c} = \text{_____ } < 0.20 (i_c - i_{bc}) \text{_____}$$

$$i_{1s} = \text{_____ } < 0.20 (i_s - i_{bs}) \text{_____}$$

or, alternatively with DMT ozonizer:

$$i_{1s} = \text{_____ } < 0.20 (i_s - I_{B1})$$

Preparations Just Before Release (2 - 0 Hours)

These preparations must be performed from 2 to 0 hours before the sounding balloon release. [Table 11 on page 48](#) presents the workflow included in preparing the radiosonde and OIF411 for a sounding with sounding software MW41 45 minutes before the launch. The steps below provide more detailed information on the preparations.

Table 11 Workflow for Ozone Sounding Preparations 45 Minutes Before Launch

Time to Launch in Minutes	Ozone Sensor	Interface OIF411	Radiosonde RS41	Sounding Software MW41	Balloon and Accessories
45	Select battery type and any supplemental heat source needed, based on the previous flight's performance.	Attach interface board to pump frame.	Attach radiosonde holder to styrofoam flight box.	Start MW41 software.	Fill the balloon and attach the detainer/unwinder/parachute.
30	Start running the ECC on ozone-free air using an external power supply for the pump motor.		Activate and condition radiosonde.	Configure software for the ozone flight.	
20	Record background current.	Connect interface to RS41.		Record background current.	
15	Connect battery to ozone sensor pump (activate battery if needed), and heater battery, if required.		Attach radiosonde to the flight box.		Prepare the radiosonde for flight. Put ECC into to flight box if it is not there yet (for prewarming in cold weather flights).
10	Take the ozonesonde construction outside to acclimatize and record surface ozone.			Check telemetry data.	Attach radiosonde to the balloon.
0				Check telemetry data.	Release the balloon.

Starting Preparations

1. Write down the following information:

Date: _____ Station : _____ Operator: _____

Ozonesonde number: _____

Manufacturer: _____

Date of manufacture: _____

Radiosonde serial number: _____

OIF411 serial number: _____

Attaching Radiosonde Holder to Flight Box

Equipment and tools needed:

- A pen for marking the positions of the holder screws.
- A screwdriver for tightening the screws.
- Radiosonde holder with three plastic dowels and three screws, included in Ozone Interface Kit RSA411.

[Figure 14 on page 50](#) shows how the radiosonde holder is attached to the flight box wall. See also the steps below.

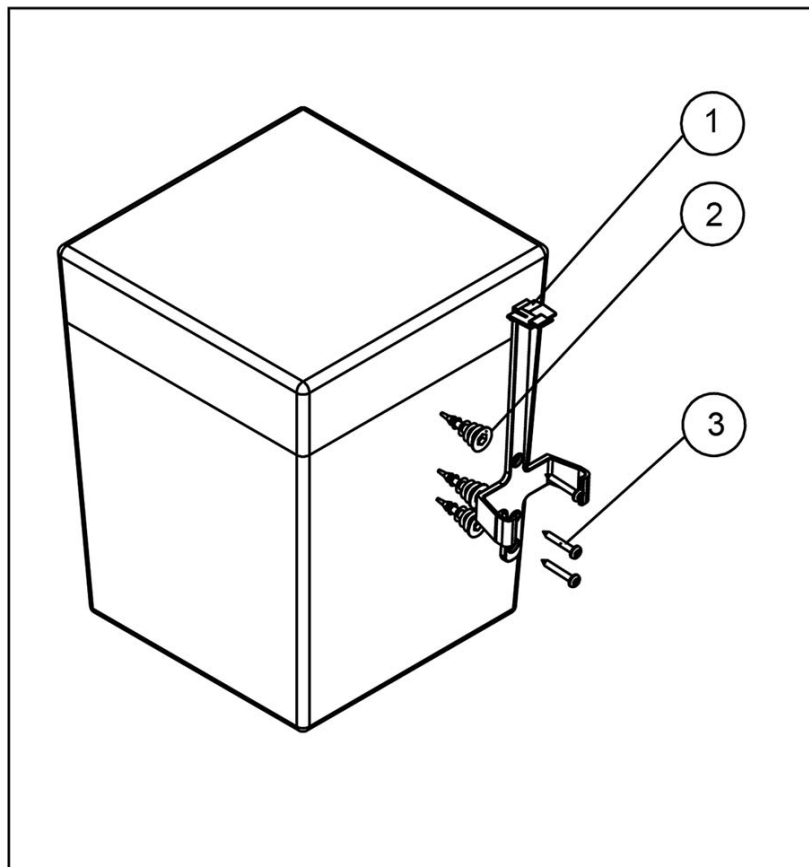

Figure 14 Radiosonde Holder Attachment

The following numbers refer to [Figure 14 on page 50](#):

- 1 = Radiosonde holder
- 2 = Dowels
- 3 = Screws

[Figure 15 on page 51](#) shows the radiosonde holder measurements and its position in the flight box wall. In the figures presented in this section, the holder is positioned according to Vaisala recommendation, according to which the radiosonde sensor boom is above the flight box wall and the holder is attached on top of the sticker.

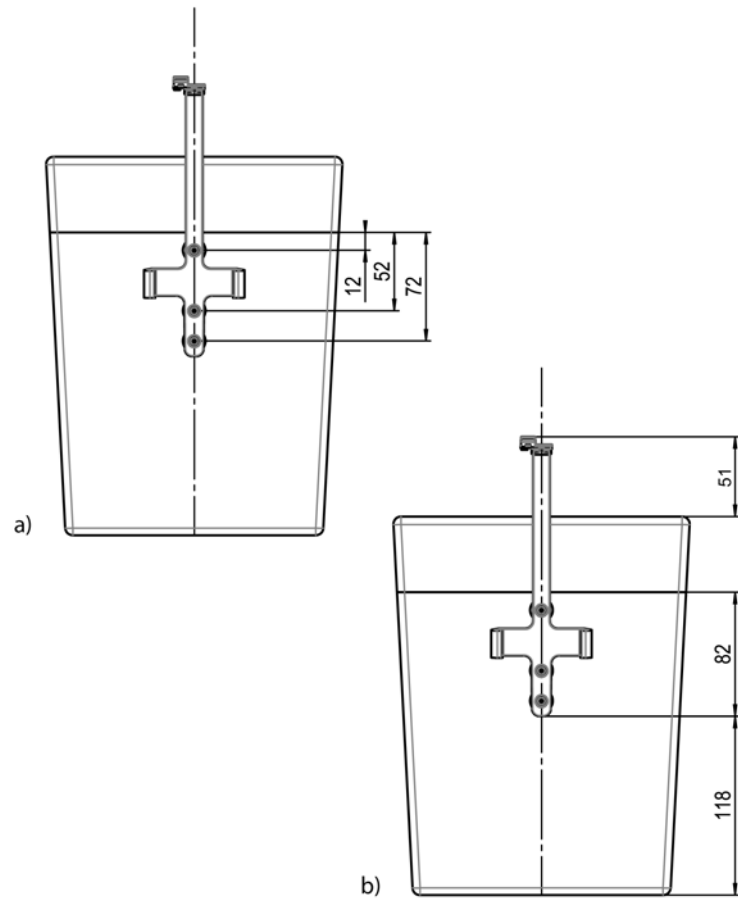

Figure 15 Radiosonde Holder Measurements (a) and Position (b)

1. The holder is attached on top of the sticker on the flight box wall. Press the radiosonde holder against the flight box wall and mark the holder screw positions with a pen.



Figure 16 **Marking the Positions of the Holder Screws**

2. Use a screwdriver to insert the dowels where the holder screw marks are. Use the three dowels included in the RSA411 kit.



Figure 17 Inserting the Dowels

3. Remove the tape cover before attaching the holder. The tape makes the radiosonde holder attachment extra secure.
4. Hold the radiosonde holder against the tape and use a screwdriver to attach it to the box wall with the screws provided in the RSA411 kit.

Attaching OIF411 to SPC's Ozone Sensor Frame

[Figure 18 on page 54](#) shows how OIF411 is attached to Science Pump Corporation's (SPC) Model ECC-6A ozone sensor frame. See also the steps below. You do not need any extra equipment to attach OIF411 to the ozone sensor frame, the wing nuts needed are included in OIF411.

For instructions on attaching OIF411 to Droplet Measurements Technologies (DMT) Model Z ozone sensor frame, see section [Attaching OIF411 to DMT's Ozone Sensor Frame on page 56](#).

CAUTION Keep the sensor in an upright position. The sensor contains liquid.

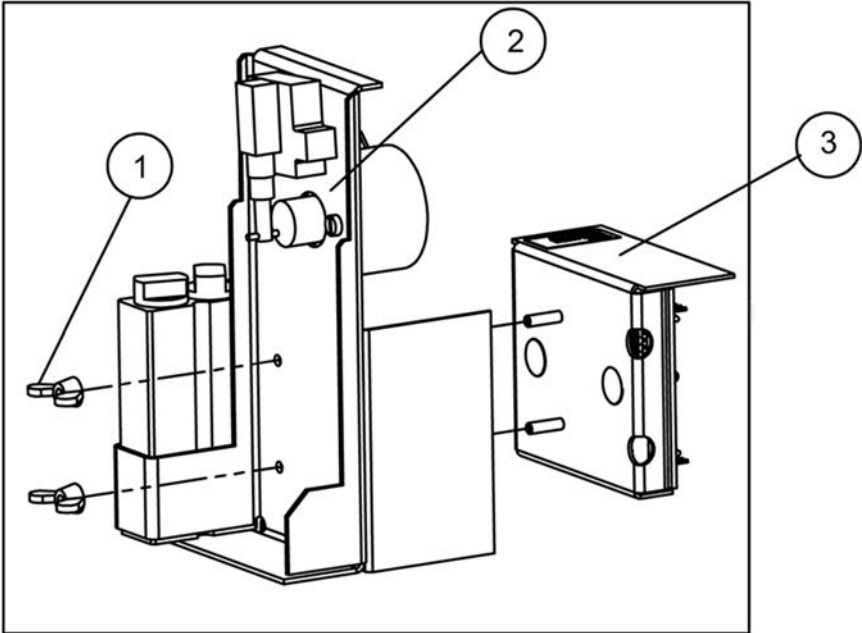

Figure 18 Attaching OIF411 to Ozone Sensor

The following numbers refer to [Figure 18 on page 54](#):

- 1 = Wing nuts
- 2 = Ozone sensor frame
- 3 = OIF411

To connect the ozone sensor frame and Ozone Interface Board OIF411:

1. OIF411 is equipped with two wing nuts at the back. Attach OIF411 to the ozone sensor with the wing nuts. See [Figure 19 on page 55](#) for an illustration.

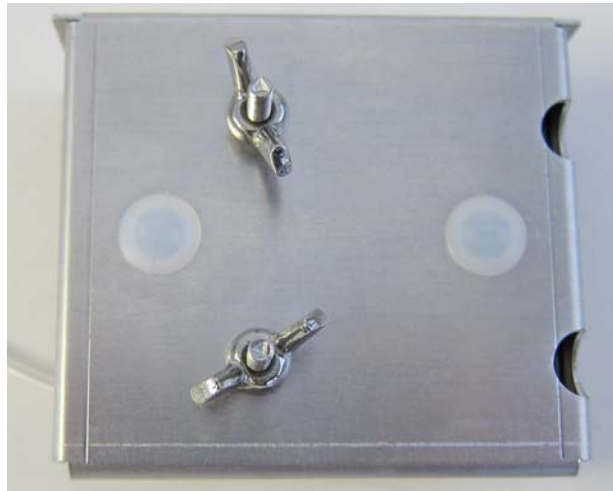

Figure 19 Wing Nuts on the Back of OIF411

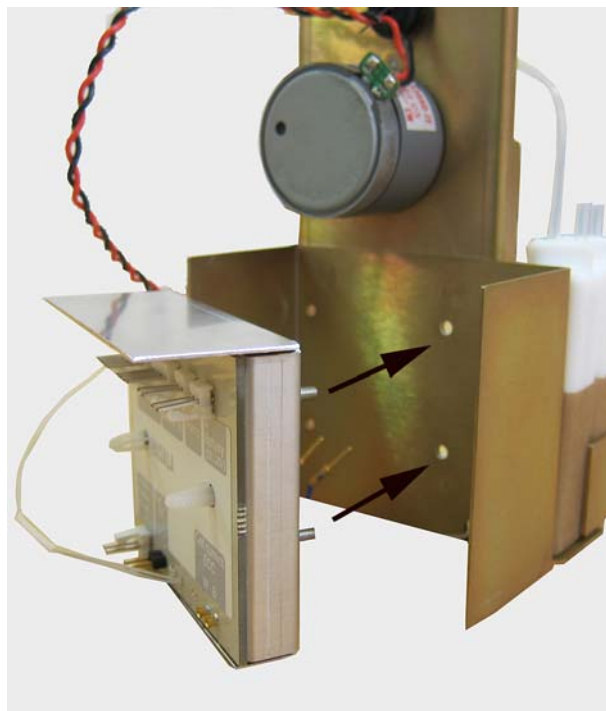

Figure 20 OIF411 Being Attached to the Ozone Sensor Frame

2. Tighten the wing nuts.



Figure 21 OIF411 Wing Nuts Tightened

Attaching OIF411 to DMT's Ozone Sensor Frame

For instructions on attaching OIF411 to Droplet Measurements Technologies' (DMT) ozone sensor frame, see the steps below. In addition to OIF411 and the ozone sensor frame, you need the following equipment:

- Two M3 nuts included in RSA411 Ozone Interface Kit
- Drill with applicable drill bits
- Socket wrench for M3 nuts
- Screwdriver

CAUTION

Keep the sensor in an upright position. The sensor contains liquid.

[Figure 22 on page 57](#) shows Droplet Measurements Technologies Model Z ozone sensor frame.

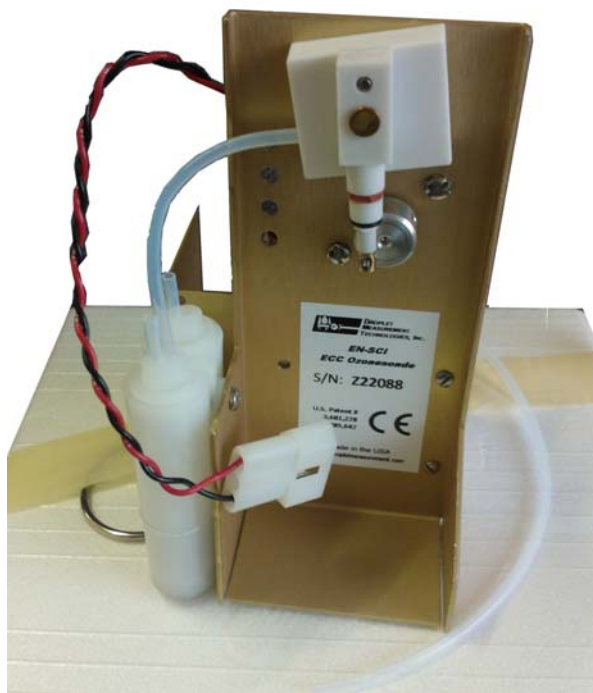

Figure 22 Droplet Measurements Model Z Sensor

To connect the ozone sensor frame and Ozone Interface Board OIF411:

1. Remove the wing nuts attached to OIF411.
2. Use a drill to make the holes in the ozone sensor frame bigger.



Figure 23 Drilling the Ozone Sensor Frame Holes

3. Attach OIF411 to the ozone sensor frame with the two M3 hex nuts, a screw driver and a socket wrench. Tighten the nuts.



Figure 24 Ozone Sensor Attached to the DMT Frame with M3 Nuts

Connecting Ozone Sensor Wires to OIF411

Connect the ozone sensor wires to Ozone Interface Board OIF411.

The terminals on OIF411 are marked with a sticker attached on the card. See [Figure 25 on page 59](#) for an example. The numbers in the figure refer to [Table 12 on page 59](#).

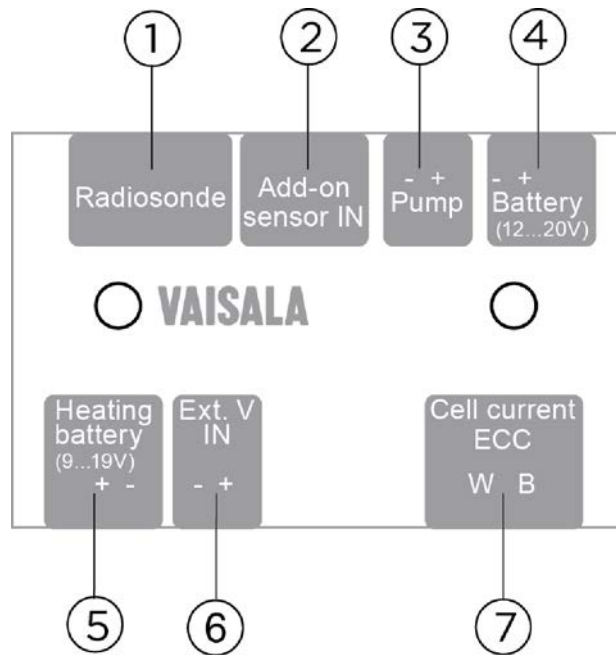

Figure 25 OIF411 Terminals Marked on Sticker

Table 12 OIF411 Terminals

Number	Connection	Cable Code
1	Radiosonde interface	CBL210224
2	Add-on sensor IN for optional XDATA sensors	
3	Pump motor	CBL210282
4	Ozone pump motor battery	CBL210225
5	Heating battery	CBL210295
6	Extra terminal	
7	SPC sensor W = white cable B = blue cable	

The white wire from the anode is connected to the terminal on the corner of the interface marked with W. The blue wire from the cathode is connected to the terminal marked with B.

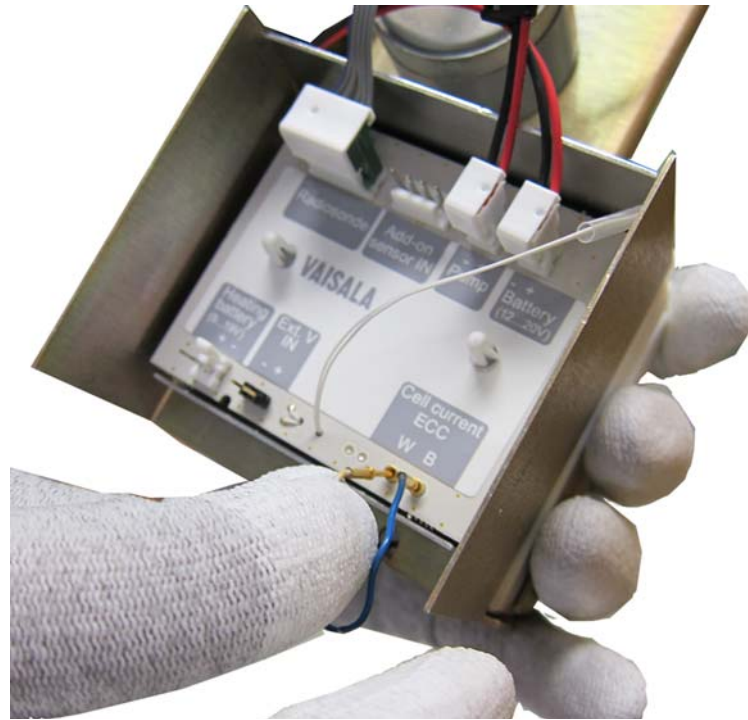

Figure 26 Connecting Sensor Wires to OIF411

Preparing the Radiosonde and OIF411

CAUTION

To avoid any problems with the sounding, do not use the sensor loaded (pump-powered) with solutions, if the sensor is not connected to a powered interface, or if the anode and cathode wires are connected. The pump is allowed to be used only with NO-OZONE, or when the destruction filter is connected. Never use HI-OZONE.

Connecting Ozone Sensor Pump to OIF411

- Cable needed: CBL210282

Connect the cable to the OIF411 terminal marked **Pump**.

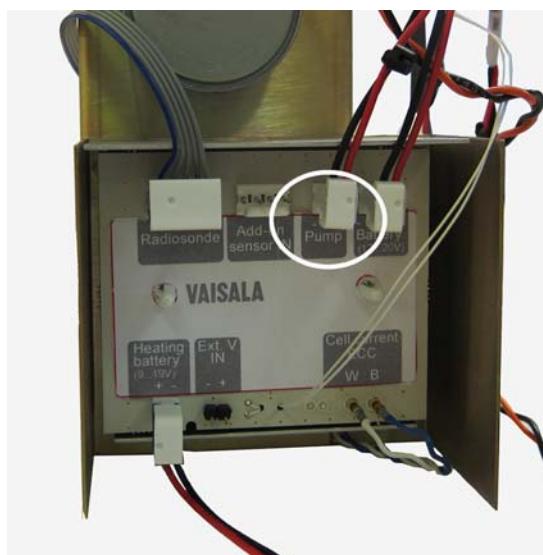

Figure 27 Connecting Ozone Sensor Pump Cable

Connecting Ozone Pump Battery to OIF411

- Cable needed: CBL210225

Connect the ozone pump battery to OIF411 terminal marked **Battery (12 ... 20 V)**. At a later stage, place the battery in the empty compartment on the side of the flight box.



Figure 28 Connecting Ozone Sensor Battery Cable

Connecting Thermistor Cable to Ozone Sensor Pump

Insert the thermistor into the hole in the pump base of the ozone sensor by pushing the thermistor hose into the hole, as shown in [Figure 29 on page 63](#). In the SPC sensor, the hole is below the air outlet of the pump.

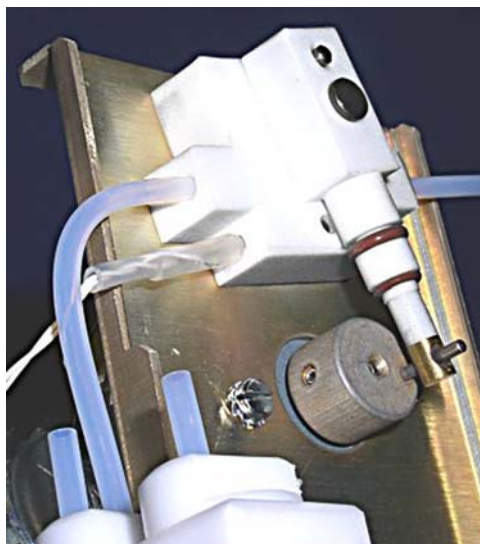

Figure 29 SPC ECC-6A with Thermistor Assembled

In the DMT sensor, the temperature measuring hole is on the opposite side of the pump (and is connected through the frame).



Figure 30 DMT Model Z with OIF411 Temperature Sensor Assembled

Connecting Additional Sensor Cable to OIF411

If you are using an additional sensor in the sounding, use the terminal marked **Add-on sensor IN** for the additional sensor cable.

Connecting Heating Battery to OIF411 (Optional)

- Cable needed: CBL210295

The heating battery is used in extreme conditions. Heating turns on automatically when the ozone pump temperature drops under $+5\text{ }^{\circ}\text{C}$, and turns off when the temperature rises above $+7\text{ }^{\circ}\text{C}$. There is no risk of overheating the box. However, the applicability of the heating should be checked on each site separately.

Connect the heating battery wire to the **Heating battery** terminal on OIF411. The red wire is connected to the terminal marked with +, and the black wire is connected to the terminal marked with -.

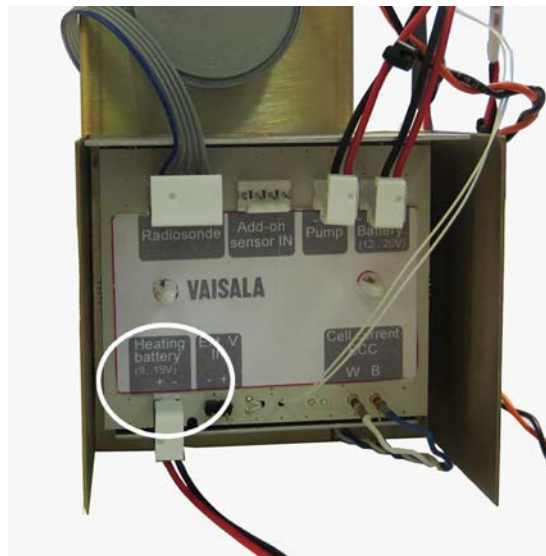

Figure 31 Connecting Heating Battery

Attach two-sided tape to the side and bottom of the battery to attach it to the sensor frame.



Figure 32 Two-Sided Tape Attached to the Battery

Make sure to pass the battery wires between the ozone sensor frame wall and the ozone sensor top cover and make sure that they are not twisted or under the sensor frame. See [Figure 33 on page 65](#) for an illustration.



Figure 33 Battery Wires Running Between the Ozone Sensor Frame Wall and the Ozone Sensor

Preparing the Radiosonde with Ground Equipment

CAUTION

To be able to prepare an ozone sounding with MW41, you must import and activate the following scripts: **OzoneCalculations.py**, **OzoneMain.py**, and **OIF411.py**. The scripts are included on the MW41 installation DVD, in folder ScriptLibrary\CalcOzone. The ozone sounding cannot be completed if any of these scripts is missing.

Import the scripts to the same Script Group and select OzoneMain.py as the main script. Make sure that Script group is set active. You do not need to set a command line argument. For more instructions, see MW41 on-line help.

1. Start MW41 sounding software, if you have not started it yet, and log in.
2. Attach the ozone destruction filter to the pump inlet tube.
3. Place the RS41 radiosonde on the ground check device. The radiosonde is switched on when you place it on the ground check device. The message "Preparation in progress" will be displayed in MW41.

CAUTION

Do not connect the Ozone Interface Board OIF411 to the radiosonde while the radiosonde is placed on the ground check device. Connecting OIF411 during the ground check will interrupt the preparations and MW41 will return to the Radiosonde selection window.

4. Before the preparation phase is completed, scroll the MW41 page down to the Special sensor window, and select **Ozone** from the drop-down list.
5. Fill in the information needed and click **Apply**.

During this phase, the radiosonde LED light is red, but you can ignore it. It does not indicate an error at this point.

NOTE

The ASOPOS panel recommends 3.0 cm³ for cathode solution volume.



The screenshot shows a 'Special sensor' configuration window. At the top, 'Ozone' is selected in a dropdown menu. Below it, the 'Sensor' is set to 'SPC-6A'. Other parameters include 'Calibration pressure' at 1012 hPa, 'Cathode solution volume' at 2.5 cm³, 'Median filter window radius' at 4, and 'Pump air flow rate' at 27 s/100cm³. There are 'Apply' buttons at the bottom right. At the bottom of the window, there are fields for 'Sensor background current' (in μA) and 'Reference value' (in μA), with a 'Copy' button next to the reference value field. A note at the very bottom states: 'Copy or insert value to be used in the current sounding.'

Figure 34 Ozone Sensor Information

During the ground check preparations, the radiosonde status in MW41 might display an error with the message "No add-on sensor data (filtered)". You can ignore this message and proceed with the preparations, it has no effect on the ozone sounding.

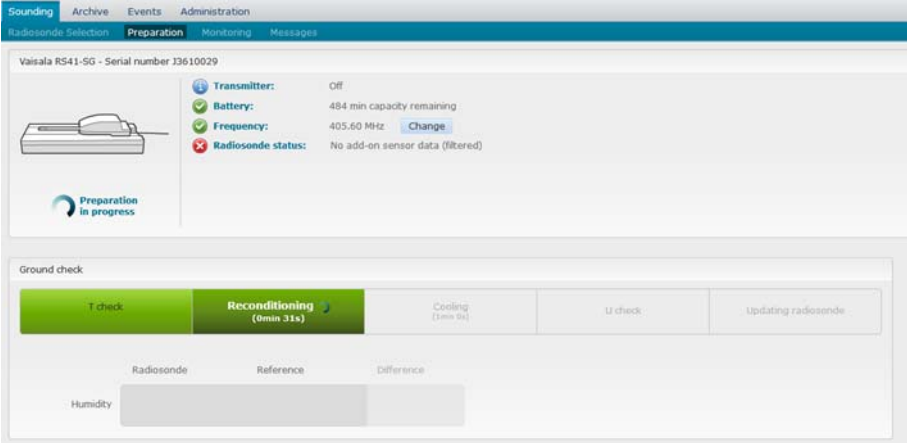

The screenshot shows the 'Radiosonde Preparation in Progress' interface. At the top, there are tabs for 'Sounding', 'Archive', 'Events', and 'Administration'. Below these are sub-tabs: 'Radiosonde Selection', 'Preparation', 'Monitoring', and 'Messages'. The main content area shows the status of a 'Vaisala RS41-SG - Serial number J3610029'. It includes a 'Preparation in progress' icon and a list of status items: 'Transmitter: Off', 'Battery: 484 min capacity remaining', 'Frequency: 405.60 MHz (with a 'Change' button)', and 'Radiosonde status: No add-on sensor data (filtered)'. Below this is a 'Ground check' section with a progress bar showing 'T check', 'Reconditioning (0min 31s)', 'Cooling (2min 0s)', 'U check', and 'Updating radiosonde'. At the bottom, there is a table for 'Humidity' with columns for 'Radiosonde', 'Reference', and 'Difference'.

Figure 35 Radiosonde Preparation in Progress

- When the message "Waiting for background current" is displayed, remove the radiosonde from the ground check device.

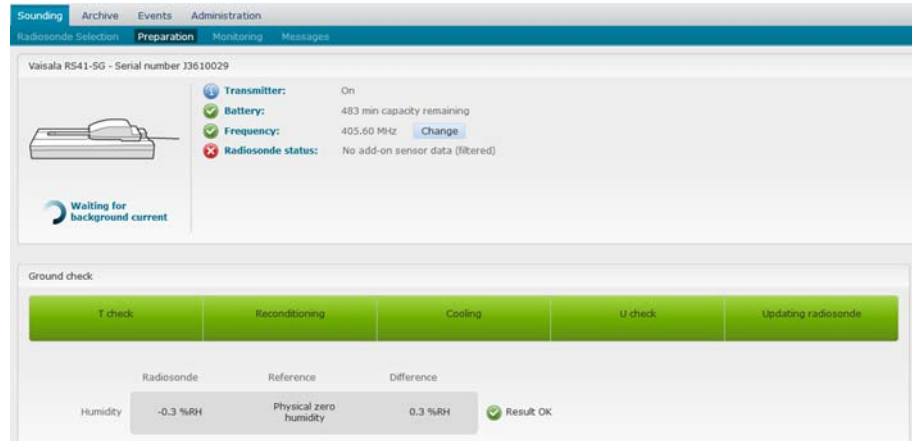

Figure 36 Waiting for Background Current

- Connect OIF411 to the radiosonde using cable CBL210224. Do as explained below:

CAUTION

Do not touch or hit the radiosonde sensors on the sensor boom. By carefully handling the radiosonde and the sensor boom, you ensure that the radiosonde functions properly during the sounding.

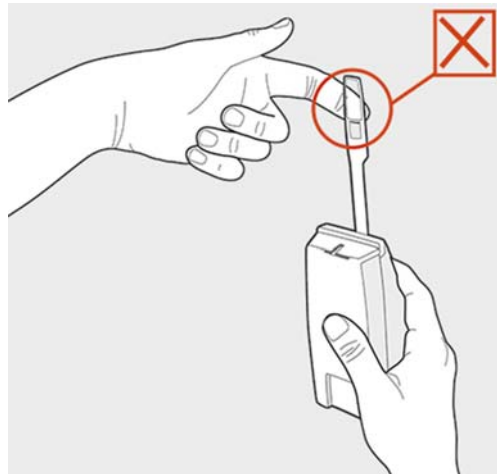

Figure 37 Do Not Touch the Radiosonde Sensors

Connect the radiosonde cable to the interface terminal marked **Radiosonde**.



Figure 38 Connecting Radiosonde Cable

Connect the interface to the radiosonde:

First check that none of the pins on the radiosonde interface are deformed. After this, firmly push the connector to the interface connector pins located inside the radiosonde, see [Figure 40 on page 70](#) for an example.



Figure 39 Checking Radiosonde Interface Connector



Figure 40 OIF411 Connected to Radiosonde Interface Connector

After the connection, the radiosonde LED light is blinking green.

8. Attach the radiosonde to the holder in the flight box as instructed below.

CAUTION

Do not touch or hit the sensors on the sensor boom. By carefully handling the radiosonde and the sensor boom, you ensure that the radiosonde functions properly during the sounding.

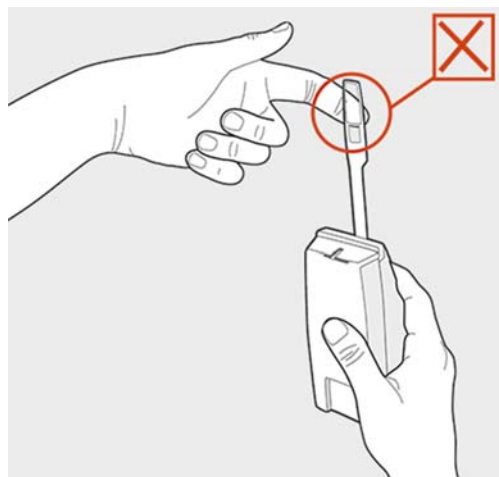

Figure 41 Do Not Touch the Radiosonde Sensors

NOTE

Detailed capacity information on the radiosonde battery is available in the radiosonde data sheet. OIF411 interface reduces the battery operating time by approximately 2 to 4%. If there are any delays in the sounding preparations or before the sounding starts while the radiosonde is powered from the battery, you can switch off RS41 by pressing the power switch. Switch the radiosonde back on before launching the balloon.

Hold the radiosonde holder with your other hand and place the radiosonde's bottom end to the holder first. See [Figure 42 on page 71](#).



Figure 42 **Attaching Radiosonde to the Holder**

Use your finger to push the top part of the holder against the radiosonde so that the radiosonde is tightly attached to the holder.



Figure 43 Pushing the Holder into Place

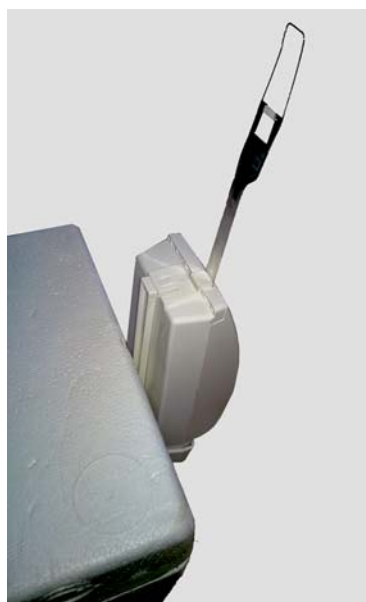

Figure 44 Radiosonde RS41 Attached to the Holder

If you attach the radiosonde in a lower position than shown here, push the holder against the flight box wall.

9. After attaching the radiosonde, place the ozone sensor into the flight box. In this step, item a. below explains inserting SPC ozone sensor to the flight box. See item b. for DMT sensor instructions.
 - a. For an example of the SPC sensor inside the flight box, see [Figure 45 on page 73](#). Make sure that the wires and tubes are led through the grooves in the flight box, indicated with the numbers in the figure.

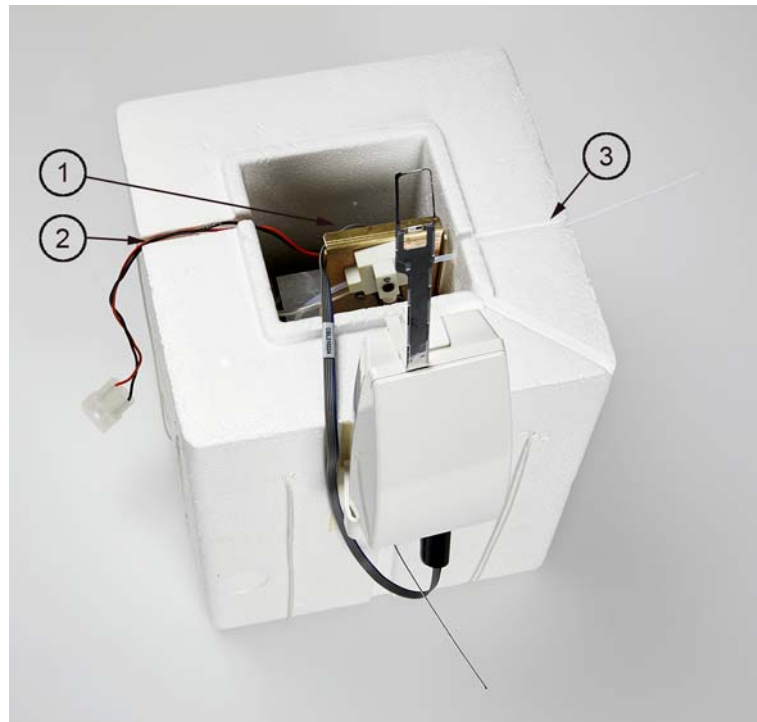

Figure 45 SPC Ozone Sensor inside the Flight Box

The following numbers refer to [Figure 45 on page 73](#):

- 1 = Ozone sensor placed inside the flight box
- 2 = Pump motor battery wires led through the groove
- 3 = Air tube led through the groove

- b. For an example of the DMT sensor inside the flight box, see [Figure 46 on page 74](#). Make sure that the wires and tubes are led through the grooves in the flight box.

CAUTION

In case of DMT sensor, make sure to place the flight box cover (number 1 in [Figure 46 on page 74](#)) and the ozone sensor inside the box (number 2) in the correct position and leave enough headspace for the pump. The cover must not touch the pump as it might prevent the pump from running. Number 3 indicates the radiosonde position on the flight box wall.

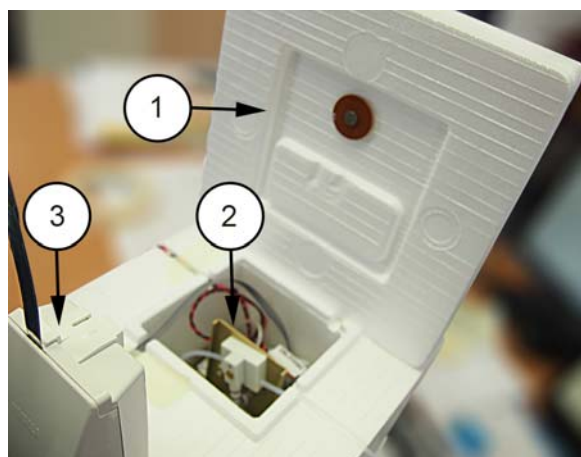

Figure 46 DMT Ozone Sensor inside the Flight Box, Cover About to be Closed

The following numbers refer to [Figure 46 on page 74](#):

- 1 = Flight box cover
- 2 = Ozone sensor placed inside the flight box
- 3 = Radiosonde RS41-SG

Optionally, you can prepare the ozone sensor outside the flight box. The GAW report 201 recommends setting the ozone sensor into the flight box during the measuring of the background current prior to the flight, but, for practical reasons, you can also prepare the ozone sensor outside the flight box.

- 10. Do not connect the pump motor wires to the battery yet, leave the connectors outside the flight box.
- 11. In this step, item a. below explains finalizing the flight box for SPC sensor. See item b. for DMT sensor instructions.
 - a. In case of SPC sensor, close the cover of the flight box and tape the seam between the cover and the body of the box. Do

not tape the hanging strings. See [Figure 53 on page 81](#) for an example.

NOTE

Do not tape over the air outlet and air intake tube, as the measuring gas must be allowed to move in and out of the sensor box. See [Figure 47 on page 75](#) for an illustration.

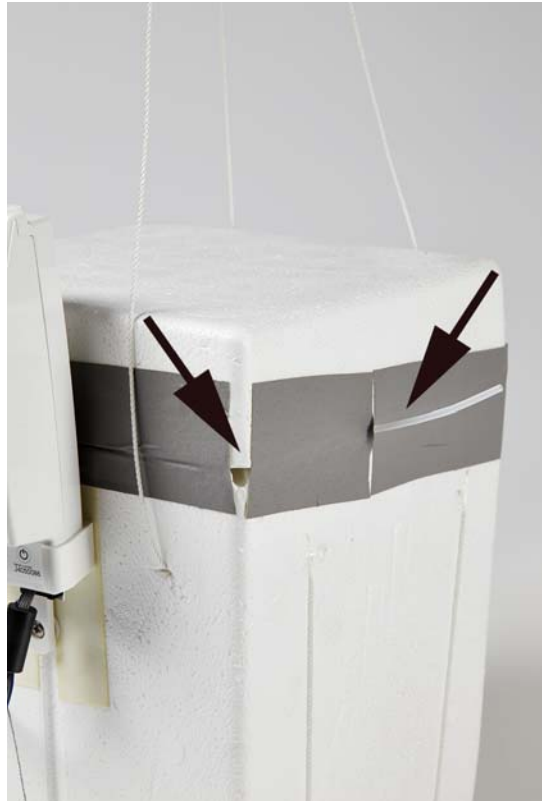

Figure 47 Air Outlet Hole and Air Intake Tube Not Taped Over

- b. In case of DMT sensor, it is a good idea to attach the flight box string with another string in two places (indicated with the arrows in [Figure 47 on page 75](#)) so that the string does not hit the radiosonde sensor boom during the flight.

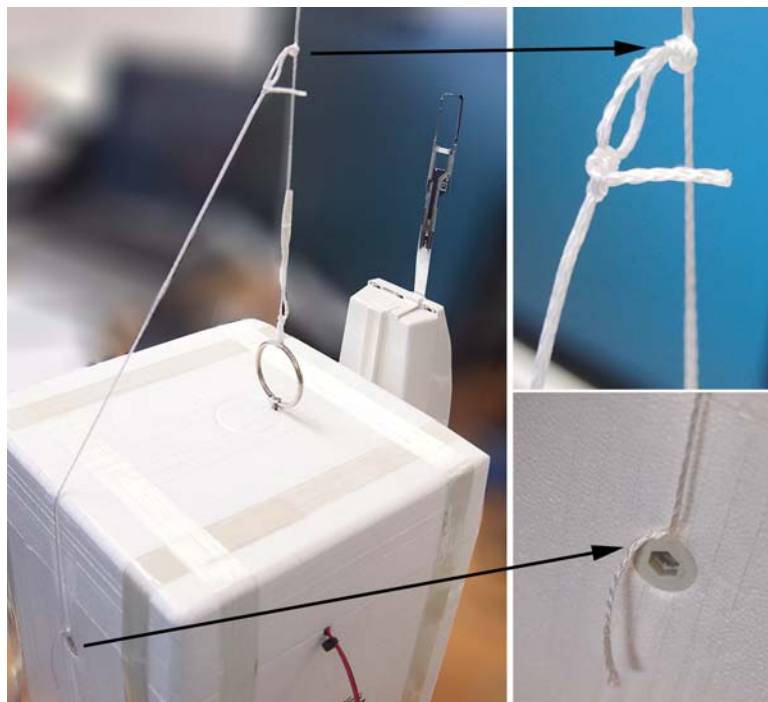

Figure 48 Supported Flight Box String in DMT Ozone Sensor Flight Box

12. With ozone destruction filter on or zero ozone gas for sensor background current values, run the ozone sensor for 10 minutes and record the cell current I_{B2} :

Record I_{B2} : _____ μA

NOTE The I_{B2} value equals to Vaisala $I_{BG} = I_0$, used in Vaisala scripts.

NOTE Background current is measured after the flight box is closed: Close the cover of the flight box and tape the seam between the cover and the body of the box. Do not tape the hanging strings. Do not tape over the air outlet and air intake tube, as the measuring gas must be allowed to move in and out of the sensor box. See [Figure 53 on page 81](#) and [Figure 47 on page 75](#).

Always record the value indoors with destruction filter or ozone-free air connected, and after inserting the ozone sensor to the flight box.

At this stage, it is recommended to power the ozone sensor with an external power source, not with the ozone sensor battery.

13. MW41 proposes a background current. Use the value by clicking **Copy**. You can either use the **Copy** button or enter the sensor background current in MW41 and click **Apply**.



Figure 49 Entering Sensor Background Current in MW41

14. In the Monitoring window, go to the **Tabular data** tab and select **Raw ozone** from the drop-down list. Make sure that ozone data is coming through, showing reasonable ozone current and ozone flight box temperature.

Time	Raw O3 [mPa]	Current [uA]	Box temperature [°C]	Ozone pump current [mA]
07:21:16	3.88	1.086	22.73	0.000
07:21:17	3.90	1.092	22.71	0.000
07:21:18	3.98	1.114	22.71	0.000
07:21:19	0.43	0.121	22.71	0.000
07:21:23	0.26	0.072	22.71	0.000
07:21:24	0.25	0.070	22.70	0.000
07:21:25	0.25	0.069	22.70	0.000
07:21:26	0.24	0.068	22.70	0.000
07:21:27	0.24	0.067	22.71	0.000
07:21:28	0.24	0.067	22.71	0.000
07:21:29	0.23	0.066	22.71	0.000
07:21:30	0.23	0.065	22.72	0.000
07:21:31	0.23	0.065	22.72	0.000
07:21:32	0.23	0.065	22.72	0.000

Figure 50 Viewing Raw Ozone Data in MW41

The following information is displayed:

- Time: time in seconds
 - Raw O3: ozone partial pressure
 - Current
 - Box temperature
 - Ozone pump current
15. Turn off the pump and either take off the ozone destruction filter or shut off ozone-free air flow.

16. Before starting the flight, connect the ozone sensor pump to its power supply as instructed in section [Activating Pump Motor Battery on page 80](#). Now, continue with section [Constructing Sounding Accessories on page 78](#).

Constructing Sounding Accessories

Note that different installations are used depending on the components of the sounding. Always use an unwinder. An RSU stabilizer must be used if other than Vaisala-specific Totex parachute models are used.

Before you begin, see the general instructions and various sounding accessories presented in *Vaisala Guide to Sounding Preparations Technical Reference*.

The sounding construction depends on the radiosonde type and if either of the following is used:

- Radar reflector
- Parachute

NOTE

Vaisala recommends always to use the parachute in ozone soundings.
--

1. When using a Totex parachute, attach the unwinder to the ribbon loop below the parachute spreader.

As the accidental breaking of the unwinder hook might cause the ozone sounding box to fall with great speed, Vaisala recommends that you tie the unwinder to the parachute spreader with a string for extra security. Thread the string through the hole in the unwinder hook (circled in [Figure 51 on page 79](#)) and tie it around the parachute spreader. Make sure the string is slightly longer and looser than the ribbon loop.

Another option is to prevent the unwinder hook from opening during the flight by tying extra-strong tape such as glass cloth tape, or equivalent, around the unwinder hook. If you do not have this kind of strong tape available, tie the unwinder with a string to the spreader, as explained above. See [Figure 51 on page 79](#). If you like, you can also use both options at the same time.



Figure 51 **Securing Unwinder with String (Left) or Tape (Right)**

CAUTION

For extra security, Vaisala recommends that you tie the radiosonde unwinder to the Totex parachute spreader with a string, or tie extra-strong tape around the unwinder hook .

2. Assemble the unwinder detainer to the radiosonde unwinder by pressing the detainer head into the radiosonde unwinder.
3. If you are using other than a Vaisala-specific Totex parachute model, or a radar reflector, connect the RSU stabilizer to the unwinder and prepare the balloon string connection. See [Figure 52 on page 79](#) for an illustration.



Figure 52 **RSU Stabilizer Attached to the Unwinder**

NOTE

When DMT Model Z ozone sensor is used, the unwinder string is firmly attached to the ring hanger.

4. Continue sounding preparations by tying the flight box string to the unwinder stick.

NOTE

Balance the radiosonde payload by moving the string knot on the bottom of the flight box, and secure it with a piece of tape.

Activating Pump Motor Battery

NOTE

Ozone sensors may also use water-activated batteries, which have their own separate activation instructions. Follow the battery manufacturers' instructions.

1. Activate the ozone sensor battery 20 minutes prior to release, and pack the battery into the compartment in the flight box. Check telemetry.
2. Take the flight box outside and connect the free-hanging battery cable with the ozone sensor battery cable. As the pump is quite noisy, you should be able to hear the ozone sensor pump running.

NOTE

Do not tape over the battery compartment, as the fumes from the battery must be allowed to move out of the box. See [Figure 53 on page 81](#) for an example.

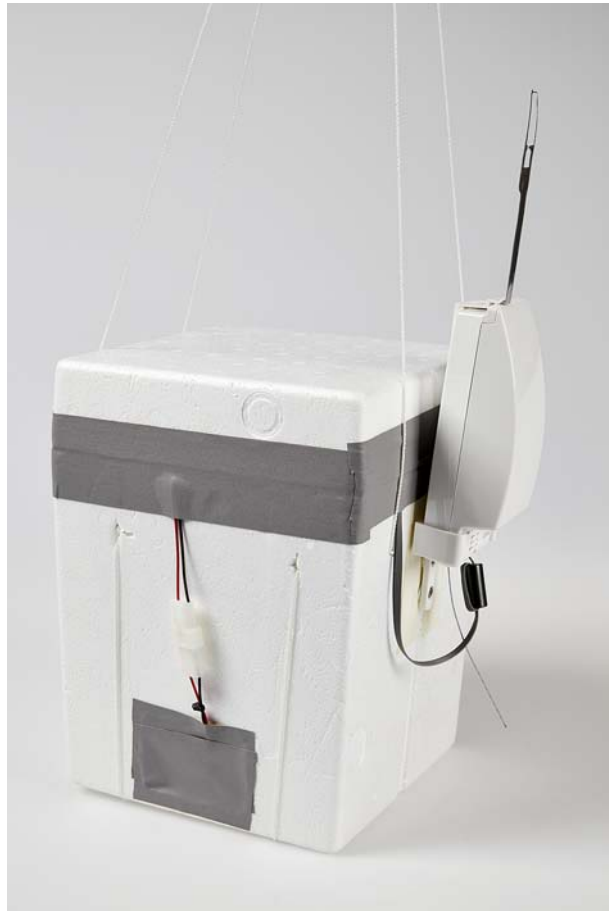

Figure 53 Taped Flight Box

Recording the Surface Ozone

NOTE

The ASOPOS panel recommends the following: It is important that, before the launch, the ozone sensor has sampled surface air for at least 5 minutes; 10 minutes is recommended.

In the MW41 Monitoring window, go to the **Tabular data** tab and select **Raw ozone** from the drop-down list. Make sure that ozone data is coming through, showing reasonable ozone current and ozone flight box temperature.

Time	Raw O3 [mPa]	Current [µA]	Box temperature [°C]	Ozone pump current [mA]
07:21:16	3.88	1.086	22.73	0.000
07:21:17	3.90	1.092	22.71	0.000
07:21:18	3.98	1.114	22.71	0.000
07:21:19	0.43	0.121	22.71	0.000
07:21:23	0.26	0.072	22.71	0.000
07:21:24	0.25	0.070	22.70	0.000
07:21:25	0.25	0.069	22.70	0.000
07:21:26	0.24	0.068	22.70	0.000
07:21:27	0.24	0.067	22.71	0.000
07:21:28	0.24	0.067	22.71	0.000
07:21:29	0.23	0.066	22.71	0.000
07:21:30	0.23	0.065	22.72	0.000
07:21:31	0.23	0.065	22.72	0.000
07:21:32	0.23	0.065	22.72	0.000

Figure 54 Viewing Raw Ozone Data in MW41

Launching the Balloon

Before launching the balloon, check the MW41 user interface to see that ozone sensor data is received. When MW41 shows the message "Ready for release", you can launch the sounding balloon.

After the release, check that the ozone data is stable in MW41.

Recording Post-Launch Data

After launching the balloon, enter the surface observation data in MW41. MW41 user interface shows the appropriate data. Use the free text field for any additional data you wish to store in the database and be available for messages.

You can also write down the information here:

Launch time:

$P_{\text{surf}} =$ _____ hPa

$T_{\text{surf}} =$ _____ °C

$U_{\text{surf}} =$ _____ % RH

Surface wind speed: _____ m/s

Wind direction: _____

Sky condition: _____

Other information: _____

CHAPTER 4

OZONE CALCULATION

This chapter describes ozone calculation in detail.

The ozone data is combined with meteorological radiosonde data: pressure (P), temperature (T) and relative humidity (U) in the ground equipment. The measuring sample interval (measures each sensor once) of Radiosonde RS41-SG is 1 second. OIF411 is scanned in phase with the radiosonde PTU measuring sequence. Therefore, all the measured data is synchronized.

Averaging and Eliminating Irrelevant Measuring Results

Noise filtering helps to eliminate erroneous data. Errors may originate from various different phenomena, for example, from electrical spikes.

The filtering is made by calculating the median of a given number of consecutive samples. The median is the middlemost sample in the order of magnitude. This algorithm cuts all remarkably higher and lower measurement results compared with other measurement results near the measurement (in a given time window). The filtering window (the number of consecutive samples, where the median is made) is given to the ground equipment during ozone sounding preparation.

The median calculation algorithm is well-defined for odd values only: number of filtering window length (1, 3, 5, 7, ...) (number of measurement samples in the window). Therefore, the filtering window is defined in the ground equipment as the window radius; from the

middle to the last sample, or, equally, from the middle to the first sample. In other words, the window radius indicates how many samples before and after the corresponding sample will be taken within the filtering window. The number of samples where the median is calculated is as follows (sample radius = window radius):

$$\text{Filter Window Length} = 2 \times \text{Window Radius} + 1$$

The sample radius is the value given for the ground equipment. If the window radius is defined as an Integer, the filter window is always an odd integer and the median algorithm is well-defined.

The ozone sensor response time is typically about 20 seconds, as indicated in the GAW report 201 (see Appendix D [Performance Review Literature on page 119](#) for details). To avoid cutting real ozone values of the measurement results, the median filtering window length must be clearly shorter than the sensor's response time. Note that the length is defined as the amount of samples. Therefore, different values for radiosondes with different sample rates must be used. A typical value for the window radius for RS41 is 4 (filtering window = 9 seconds).

The median filtering algorithm is disabled by setting the window radius to 0.

Ozone Partial Pressure Calculation

The ozone sensor operating principles are explained in detail in the sensor manufacturer manuals. To clarify the ozone calculation, the operation of the SPC ozone sensor ECC6A is explained here in brief.

Ozone Sensor Operating Principle

The ozone sensor used within the ozonesonde is an iodine-iodide redox electrochemical concentration cell. It is made of two bright platinum electrodes immersed in potassium iodide solutions of different concentrations, contained in separate cathode and anode chambers, fabricated from polytetrafluoroethylene (Teflon TFE resin). The chambers are linked together with an ion bridge that serves as an ion pathway and retards mixing of the cathode and anode electrolytes, thereby preserving their concentrations. Driving emf for the cell is derived from a difference of potassium iodide concentrations present in the two half cells. See [Figure 55 on page 87](#).

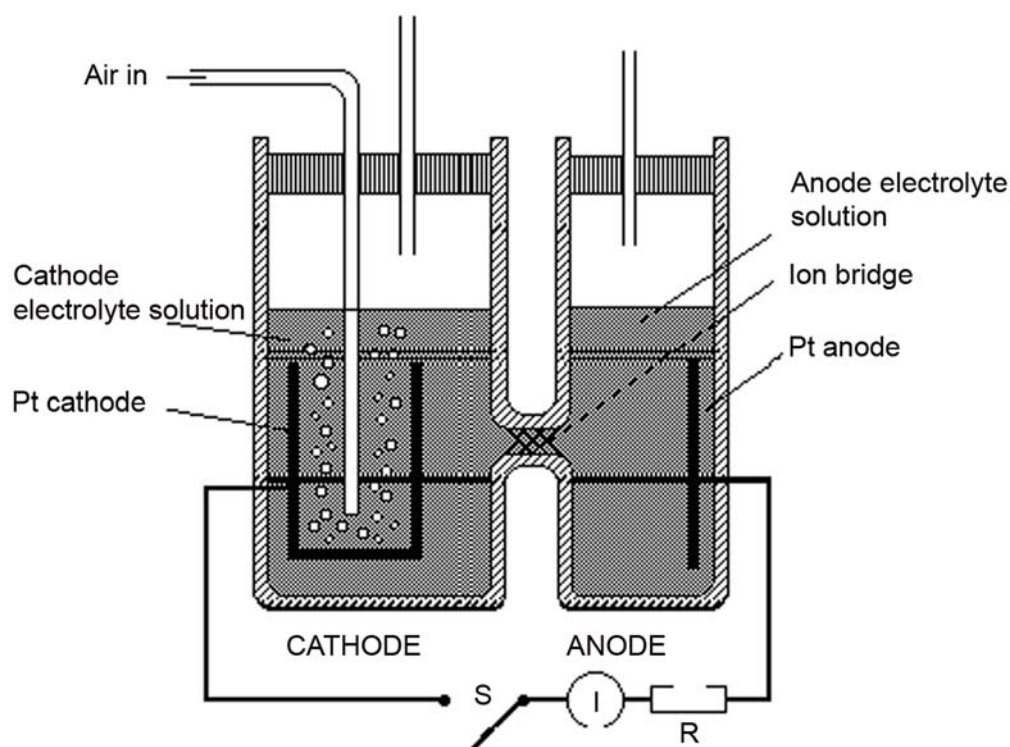
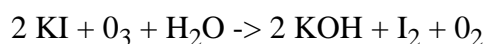

Figure 55 Electrochemical Cell Construction

A chemical reaction starts as soon as ozone (in air) flows into the cathode solution. The reaction is an iodide-iodine redox reaction. The current can be measured when the switch S is closed. R is the load resistance of the circuit.

Ozone Sensor Reactions

The cell system is shown in [Figure 55 on page 87](#). Platinum electrodes are chemically inert, and do not take part in chemical reactions. Electrochemical reactions take place in the boundary layers of the electrodes. As soon as air that contains O_3 molecules is bubbled through the cathode solution, the following total reaction occurs:



Iodine, I_2 , is formed and the I_2 concentration of the solution starts to increase. If the external circuit is closed (switch S), reaction 1 is followed by reactions 2 and 3.

In the cathode chamber:

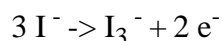

In the anode chamber:

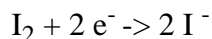

These chemical reactions result in the following statement:

ONE O₃ MOLECULE CAUSES A CURRENT OF TWO ELECTRONS

The current is measured with the OIF411 interface.

NOTE

The reaction occurs with all oxidants (such as NO₂). The chemical reaction in sensor chambers is affected by the sensor dimensions, air bubbling rate, the total liquid volume of the sensor, and the temperature of the sensor solution. These factors introduce some basic errors and variance.

Calculation of Local Ozone Values

The partial pressure of the ozone is a measure for local ozone concentration. Sometimes ppm_v values are used. Basic principles for this step of the calculations are given in the sensor manufacturer's manuals. See [Related Manuals on page 11](#). As each molecule of ozone creates a current of two electrons, ozone concentration is:

$$C = \frac{I \cdot t}{F \cdot 2 \cdot 100 \text{ml}}$$

where:

- C = ozone concentration in mmol l^{-1}
 F = $9.6485 \times 10^4 \text{ C (mol)}^{-1}$ (Faraday constant)
 I = measured current in μA
 t = pumping time for 100 ml of air (seconds)

The partial pressure of ozone (P_3) is:

$$P_3 = C \cdot R \cdot T_{air} = \frac{R}{F \cdot 2 \cdot 100\text{ml}} \cdot I \cdot T_{air} \cdot t$$

$R = 8.31451 \text{ JK}^{-1} \text{ mol}^{-1}$ (Molar gas constant)

Finally:

$$P_3 = 4.3087 \cdot 10^{-4} (I - I_{BG}) \cdot T_p \cdot t \cdot C_{ef} \cdot C_{ref}$$

where

- P_3 = partial pressure of ozone in mPa
 I = measured ozone current in μA
 I_{BG} = current caused by oxidants other than ozone (mainly O_2) in μA (I_{BG} equals to I_{B2}).
 T_p = measured airflow temperature in K from pump base.
 t = pumping time for 100 ml of air in seconds
 C_{ef} = correction due to reduced ambient pressure for pump
 C_{ref} = additional correction factor

NOTE

I_{BG} used in this manual is equal to I_0 used in the Vaisala scripts, and I_{B2} used in the GAW report 201, and the ASOPOS panel recommendations.

NOTE

Each ozone sensor manufacturer has their own recommendations for calculating I_{BG} , T_p , and C_{ef} . See [Related Manuals on page 11](#).

Background Current Correction (I_{BG})

Background current correction (I_{BG}) is caused by oxidants other than ozone (mainly O_2). Because the concentration of ozone without any additional oxidants needs to be measured, the background current has to be deducted from the measurement current.

The amount of oxidants (mainly oxygen) will decrease during sounding when ambient pressure decreases. The background current I_{BG} is counted from the following equation recommended for the SPC ECC-6A sensor.

$$I_{BG} = \frac{(A0 + A1 \times P + A2 \times P^2)}{(A0 + A1 \times P_0 + A2 \times P_0^2)} \times I_0$$

I_0 = Background current I_0 is measured using ozone destruction filter through which air is pumped during the sounding preparation activities, just before release

P = ambient pressure in hPa

P_0 = ambient pressure when I_0 is measured in hPa ~ ground pressure

$A0$ = 0.00122504

$A1$ = 0.0001241115

$A2$ = -2.687066×10^{-8}

The **Droplet Measurement Technologies Model Z** sensor recommended correction is constant:

$$I_{BG} = I_0$$

when I_0 is measured just before release during sounding setup configuration.

By setting the background current $I_o = 0$, the background current correction is disabled.

The ASOPOS panel recommends the use of a constant, pressure-independent I_{B2} in the basic equation to determine the ozone partial pressure throughout the entire vertical profile. Pressure-dependent background can be done by:

$$I_o = (P/P_0) \times I_{B2}$$

As a Vaisala equation, this is:

$$I_{BG} = (P/P_0) \times I_o$$

Pumping Time for 100 ml of Air (t)

The pumping time is measured during sounding preparations. The value is entered in the ground equipment during sounding preparations.

Measured Airflow Temperature (T_p)

All sensors use measured values in a Vaisala application.

Pump Efficiency Correction (C_{ef})

The efficiency of the SPC Model 6A Ozonesonde air sampling pump decreases with altitude. Calculated ozone partial pressures must, therefore, be corrected for the efficiency loss. Correcting factors for Model 6A pumps, with ECC sensor cathodes filled with 2.5 cm³ sensing solution and 3.0 cm³ sensing solution, are shown in [Table 13 on page 92](#), respectively. At pressure level (P) the value of C_{ef} is calculated using linear interpolation as a function of pressure.

NOTE

The ASOPOS panel recommends the use of 3.0 cm³ only.

Table 13 Ozone Partial Pressure Correction Factors

	Ozone Partial Pressure Correction Factor C_{ef}	
Atmospheric pressure hPa	Sensor cathode solution volume 2.5 cm ³	Sensor cathode solution volume 3.0 cm ³
2.0	1.160	1.171
3.0	1.124	1.131
5.0	1.087	1.092
10.0	1.054	1.055
20.0	1.033	1.032
30.0	1.024	1.022
50.0	1.015	1.015
100.0	1.010	1.011
200.0	1.007	1.008
300.0	1.005	1.006
500.0	1.002	1.004
1000.0	1.000	1.000

For other sensor manufacturers, the pump correction is very similar to the SPC ozone sensor; only the table values differ.

For Model Z, use the following table:

Table 14 Ozone Partial Pressure Correction Factors

P/hPa	C_{ef}
≤3	1.24
5	1.124
7	1.087
10	1.066
15	1.048
20	1.041
30	1.029
50	1.018
70	1.013
100	1.007
150	1.002
≥200	1

Additional Correction Factor (C_{ref})

It might be necessary to scale the ozone measurement values with an additional correction factor. For instance, if another method (such as light absorption) is usable for measuring total ozone concentration, partial pressure values can be corrected to fit the inferred total ozone value with the total ozone measurement in question.

This can be done in the ground equipment software by modifying one of the scaling calibration coefficients of the sensor. Preferably, the Pumping time for 100 ml of air is used for this correction.

$$t_{corrected} = t \times C_{ref}$$

Total Ozone Calculation

Total ozone is the integrated ozone in a column, extending from the bottom to the top of the atmosphere. Thus, it is the sum of the total ozone measured from the sounding and the estimated residual ozone (for example, total ozone after burst).

$$TOTALOZONE = \Delta\Omega_S + \Delta\Omega_R$$

where

$\Delta\Omega_S$ = Total ozone from the sounding

$\Delta\Omega_R$ = Residual total ozone

In the software used in Vaisala equipment, the results of total ozone calculation are in Dobson Units (DU).

For further information on total ozone calculation, see [Chapter 3 Ozone Calculation on page 85](#).

Total Ozone from Sounding

The total ozone from the sounding is calculated by summing up the amount of ozone in the layers between two measurement points as expressed in the equation below. When using the units indicated in the list below, the equation gives the total ozone in units of grams per square meter (g/m^2).

$$\Delta\Omega_s = \frac{\varepsilon_3}{g} \int_{p_i} p_3 d\ln p_i = \sum_i \frac{\varepsilon_3(p_{3i} + p_{3i+1})}{g^2} \ln\left(\frac{p_i}{p_{i+1}}\right)$$

where:

ε_3 = 1.6571, ratio of molecular masses of ozone and air

g = 9.80665 m/s^2 , acceleration of gravity

$p_i \dots p_{i+n}$ = Ambient pressure, [hPa]

i = Index for a measurement point

$p_{3i} \dots p_{3i+n}$ = Ozone partial pressure [mPa]

M_3 = 48.00 g/mol, molar mass of ozone

When the constants are inserted into the equation, it reduces to:

$$\Delta\Omega_s = \sum_i 0.0845 \times (p_{3i} + p_{3i+1}) \ln\left(\frac{p_i}{p_{i+1}}\right)$$

NOTE

The equation above gives the ozone in grams per square meter (g/m^2).

A commonly used unit for total ozone is Dobson Unit ($\text{DU} = 2.687 \times 10^{20}$ molecules/ m^2). To get the result in DUs, ozone grams must first be divided by molar mass of ozone 48.00 g/mol and then multiplied by Avogadro's number 6.02217×10^{23} molecules/mol. The result is ozone in molecules/ m^2 . The unit relation above is used to convert this to DUs.

The following equation gives the result in DUs when the partial pressures are given in mPa and ambient pressures in hPa.

$$\Delta\Omega_s = \sum_i 3.9449 \times (p_{3i} + p_{3i+1}) \ln\left(\frac{p_i}{p_{i+1}}\right)$$

Residual Ozone (Total Ozone after Balloon Burst)

After the balloon burst, the level of ozone is estimated by using the equation below with a constant mixing ratio ($p_{3i} = p_{3i+1} = p_{3END}$) up to ambient pressure 0 hPa. The equation changes to:

$$\Delta\Omega_R = \frac{\varepsilon_3}{g} \times p_{3END} \approx 7.8899 \times p_{3END}$$

When the pressure is given in hPa, the equation above gives the residual total ozone in DUs.

The total ozone can now be calculated from the equation:

$$TOTALOZONE = \Delta\Omega_S + \Delta\Omega_R$$

Another option is introduced in the GAW report 201. Post-calculation is possible, integrated ozone is reported, and residual can be calculated afterwards. It can also be changed in the script.

Ozone in $\mu\text{g}/\text{m}^3$

Ozone density is, by definition:

$$\zeta_3 = \frac{m_3}{V_3}$$

where m_3 = mass of ozone in volume V_3 .

The ideal gas law is

$$p_3 \times V_3 = n_3 \times R \times T$$

where

p_3 = partial pressure of ozone in mPa

n_3 = mole number of ozone

R = ideal gas constant

T = temperature in K

gives

$$V_3 = \frac{n_3 \times R \times T}{P_3}$$

Combining the equations gives

$$\zeta_3 = \frac{m_3}{n_3 \times R} \times \frac{P_3}{T} = \frac{M_3}{R} \times \frac{P_3}{T} \approx \frac{48.00 \times 10^2}{8.314510} \times \frac{P_3 \mu\text{g}}{T \text{ m}^3}$$

where:

M_3 = Molar mass of ozone, 48.00 g/mol

P_3 = Ozone partial pressure in mPa

T = Temperature in K

This means that for ozone:

$$1\text{ mPa} \approx \frac{10 \times 48.00 \times 10^2}{8.314510} \times \frac{1\ \mu\text{g}}{T_m^3} \approx 5773.04 \times \frac{1\ \mu\text{g}}{T_m^3}$$

Accuracy of Ozonesonde Measurement

Certain sources of inaccuracy must be kept in mind when considering errors in ozone measurements. Errors can originate from the ozone sensor cell, the interface (converter), temperature and flow rate measurement, telemetry, or they can be random errors. The measurement procedure affects the accuracy. For example, if you measure only ozone partial pressure, you can do measurements in a way which is slightly different from the method you use when calculating total ozone in the end. It is also possible to improve measurement accuracy by developing the measurement methods in the sensing system.

Basic sources for errors and differences between measurement systems (the ECC system, light absorption measurement) are quite well known. Relevant literature is also available. See Appendix D [Performance Review Literature on page 119](#).

NOTE

The latest detailed technical data for the radiosonde and OIF411 can be found on the Vaisala website, www.vaisala.com.

NOTE

Detailed specifications for the ozone sensors are available directly from the manufacturers or from Vaisala.

CHAPTER 5

OZONE INTERFACE BOARD OIF411 DATA

This chapter explains the data received from Ozone Interface Board OIF411, and how it is interpreted.

Interpreting OIF411 Data

Measurement Data

When Radiosonde RS41 is connected to Ozone Interface Board OIF411, it sends the OIF411 measurement data through the additional sensor interface. The following information is contained:

- Instrument type and number
- Ozone pump temperature
- Ozone current
- Battery voltage
- Ozone pump current
- External voltage measured once per second

OIF411 measurement data contains the following information:

xdata= <Instrument type is 05><Instrument number is 01><Ozone pump T [0.01 °C]><Ozone current [0.0001uA]><Battery voltage [0.1V]> <Ozone pump current [1 mA]><Ext. voltage [0.1V]>CR

This means that if OIF411 sends

xdata=050108CA186A0750B637CR

it is interpreted as shown in [Table 15 on page 100](#):

Table 15 OIF411 Data Interpretation 1

	Instrument Type 2 Bytes	Instrument Number 2 Bytes	Ozone Pump T [0.01 °C] 4 Bytes. MSB bit is a sign bit.	Ozone Current [0.0001uA] 5 Bytes	Battery Voltage [0.1V] 2 Bytes	Ozone Pump Current [1 mA] 3 Bytes	Ext. Voltage [0.1 V] 2 Bytes
Hex ASCII	05	01	08CA	186A0	75	0B6	37
Interpreted as	5	1	22.50	10.0000	11.7	182	5.5

ID Data

The radiosonde also sends OIF411 ID data, which contains:

- Instrument type and number
- OIF411 serial number
- Diagnostics word
- Software version once per minute

OIF411 ID data replaces OIF411 measurement data, but not the additional sensor data, sent once per minute.

The OIF411 ID data contains the following information:

xdata= <Instrument type is 05><Instrument number is 01><OIF serial number><diagnostics word><SW version><I>CR.

This means that if OIF411 sends

xdata=0501G12345670001000AICR

it is interpreted as shown in [Table 16 on page 101](#):

Table 16 OIF411 Data Interpretation 2

	Instrument Type 2 Bytes	Instrument Number 2 Bytes	OIF411 Serial Number 8 Bytes	Diagnostics Word 4 Bytes	Software Version 2 Bytes	ID Data
Hex ASCII	05	01	G1234567	0001	000A	I
Interpreted as	5	1	G1234567	Bit0 set (=calibration not done)	0xA=10 dec -> SW version is 10/100= 0.10	Ignore Use data length to distinguish ozone and ID data.

Additional Data

If additional xdata-compatible sensor is connected to OIF411, it receives data from the additional xdata sensor, increments instrument number by 1, and sends this data immediately after receiving the CR.

Additional sensor data can be in any order (except that the OIF411 data always comes first), meaning that the instrument numbers are not in an ascending order. For example:

```
xdata=050108CA186A0750B637CRxdata=020300090009000900090
0090009CRxdata=10021FF44487A04E0410018FLFCR
xdata=0304001000100010001000100010CR
```

If additional sensor CFH is connected to OIF411, OIF411 sends

```
xdata=050108CA186A0750B637CRxdata=10021DB6BC879
5200443018FLFCR
```

where LF = line feed, CR = carriage return.

CHAPTER 6

STORAGE AND TRANSPORTATION

This chapter provides information for the transport and storage of the product.

Storage

Ozone Interface Kit RSA411 must be stored and used properly in accordance with applicable instructions, User's Guide, and specifications issued by Vaisala.

Proper storage conditions must fulfill the following requirements:

Ozone Interface Kit RSA411 must be stored in a dry, ventilated indoor storage space, and within the following key environmental limits (ref. IEC 60721-3-1 class 1K2):

- Temperature +5 °C to +40 °C
- Relative humidity below 85%

Transportation

Ozone Interface Kit RSA411 must be transported in the original shipping package. The package is designed and built to survive and protect its contents in the environmental conditions described herein with the terminology and standards per standard: IEC 60721-3-2. Transportation of OIF411 requires climatic conditions 2K2 and mechanical conditions 2M1 of this standard:

- Transportation in weather-protected conditions.
- Transportation using conventional means (car, truck, and/or aircraft), with free fall not exceeding 0.25 m in any circumstances.
- Following additional markings on packaging.

CHAPTER 7

TECHNICAL SUPPORT

This chapter presents information about technical support.

Product Returns

If the product is found faulty, please follow the instructions below to speed up the process and to avoid extra costs to you.

1. Read the radiosonde warranty information.
2. Contact Vaisala technical support via e-mail or fax and request for RMA (Return Material Authorization) and shipping instructions.
3. Proceed as instructed by Vaisala technical support and provide the failure report as requested.

NOTE

RMA must always be requested from Vaisala technical support before returning any faulty material.

Technical Support

For technical questions, contact the Vaisala technical support:

E-mail helpdesk@vaisala.com

Fax +358 9 8949 2790

APPENDIX A

DIGICORA MW41 OZONE DATA

This appendix explains the files containing the ozone-related data in MW41. In MW41, ozone-related data is created with the help of scripts. For further information on preparing and monitoring an ozone sounding with MW41, see the on-line help embedded in the sounding software.

Calculating Ozone Data in MW41

Ozone data is calculated by the scripting engine using raw ozone and EDT data. This information, along with the calculated ozone, can be archived for further inspection, for example, simulation. The MW41 installation DVD contains script interface documentation which provides more information on using the scripts. Ozone calculation is implemented with three script files:

- OzoneMain.py
- OzoneCalculations.py
- OIF411.py

Reporting Ozone Data in MW41

You can use the report template editor in MW41 to create an ASCII output of the calculated ozone data. The data may also be programmatically accessed via the script interface during the sounding. The ozone-related data can be exported in the following files:

calc_ozone.tsv and *specsens.tsv*. For information on creating a report in MW41, see the on-line help.

Below is an example of an ozone data report output:

Elapsed time	HeightMSL	O3	BoxTemperature	IntegratedOzone	ResidualOzone	O3Voltage	O3Aux
s	m	mPa	°C	DU	DU	V	
0	28	1.57	23.58	0.00	12.38	13.414	107.865
1	34	1.56	23.58	0.01	12.30	13.700	108.000
2	38	1.53	23.58	0.02	12.10	13.900	110.000
3	42	1.53	23.59	0.02	12.10	13.800	104.000
4	48	1.55	23.59	0.03	12.24	13.500	107.000
5	56	1.57	23.59	0.04	12.39	13.600	112.000
6	64	1.57	23.59	0.05	12.35	13.600	111.000
7	70	1.57	23.59	0.06	12.36	13.700	109.000
8	77	1.57	23.58	0.07	12.39	13.800	109.000
9	84	1.64	23.58	0.09	12.95	13.700	106.000
10	92	1.64	23.58	0.10	12.91	13.500	105.000
11	99	1.64	23.58	0.11	12.96	13.700	120.000
12	105	1.65	23.57	0.12	12.99	13.900	108.000
13	108	1.64	23.57	0.12	12.97	13.700	107.000
14	111	1.67	23.57	0.13	13.14	13.600	113.000
15	116	1.67	23.57	0.14	13.19	13.700	112.501

Figure 56 Example of an MW41 Ozone Data Report Output

Archived Ozone Data in MW41

The calculated ozone data is stored in XML format in a zipped .mwX sounding archive file. Extract the .zip file to access the .xml file. The following tables in the archive file contain ozone-related data:

Additional Sensor Data from RS41

Table 17 AdditionalSensorData

Column Name	Type	Description
SOUNDINGIDPK	String	Unique sounding ID
RADIORXTIMEPK	Double	Radio time [s]
INSTRUMENTTYPEPK	String	Instrument type identifier
INSTRUMENTNUMBERPK	String	Instrument number
MEASUREMENTOFFSET	Double	Measurement time offset of the additional sensor data [s]
DATASRVTIME	String	Data server timestamp [yyyy-MM-dd HH:mm:ss.fff]
GPSTIMEOFFSET	Byte	Offset to the frame's GPS time [1/20 s]
XDATA	String	XData from additional sensor

Additional Sensor Data from RS92

Table 18 RS92SpecialSensorData

Column Name	Type	Description
SOUNDINGIDPK	String	Unique sounding ID
RADIORXTIMEPK	Double	Radio time [s]
DATASRVTIME	String	Data server [yyyy-MM-dd HH:mm:ss.fff]
HEADERDATA	UShort	Interface and sensor type
SENSORDATA	String	Sensor data

Calculated Ozone Data

Ozone layer data with pressure correction is applied.

Table 19 CalculatedOzone

Column Name	Type	Description
SOUNDINGIDPK	String	Unique sounding ID
RADIORXTIMEPK	Double	Radio time [s]
DATASRVTIME	String	Data server [yyyy-MM-dd HH:mm:ss.fff]
PARTIALPRESSURE	Double	Calculated ozone partial pressure [mPa]
BOXTEMPERATURE	Double	Sensor box temperature [Kelvin]
O3CURRENT	Double	Bias and pressure corrected current [uA]
INTEGRATEDOZONE	Double	Ozone accumulated up to the current sounding level [DU] (Dobson Unit)
RESIDUALOZONE	Double	Estimated residual ozone above the current sounding level [DU] (Dobson Unit)
VOLTAGE	Double	OIF92: Channel 3 data OIF411: Battery voltage measurement [V]
AUX	Double	OIF411: ozone pump current value OIF92: channel 4 data

OIF411 or OIF92 Ozone Parameters

Table 20 OIF411Parameters/ OIF92Parameters

Column Name	Type	Description
SOUNDINGIDPK	String	Unique sounding ID
DATASRVTIME	String	Data server [yyyy-MM-dd HH:mm:ss.fff]
SENSORTYPE	String	Sensor type code
SERIALNUMBER	String	OIF411: null OIF92: serial number
CALIBRATIONPRESSURE	Double	Applied calibration pressure [hPa]
SOLUTIONVOLUME	Double	Cathode solution volume [cm3]

Table 20 OIF411Parameters/ OIF92Parameters (Continued)

Column Name	Type	Description
MEDIANFWRADIUS	Double	Median filter window radius
FLOWRATE	Double	Pump airflow rate [s/100 cm ³]
IOFFSET	Double	OIF411: null OIF92: offset correction for current measurement
IREFLIN	Double	OIF411: null OIF92: Iref linear temperature coefficient [1/ k]
IREFQUAD	Double	OIF411: null OIF92: Iref quadratic temperature coefficient [1/ K ²]
IREFZEROC	Double	OIF411: null OIF92: Iref at 0 C temperature [uA]
RNTC25	Double	OIF411: null OIF92: Sensor thermistor resistance at 25 C temperature [Ohm]
VREFCH3	Double	OIF411: null OIF92: Reference value for voltage channel [V]
VREFCH4	Double	OIF411: null OIF92: Reference value for AUX channel [V]
BGCURRENT	Double	Sensor background current [uA]

Ozone Results

Summary of calculated ozone data.

Table 21 OzoneResults

Column Name	Type	Description
SOUNDINGIDPK	String	Unique sounding ID
DATASRVTIME	String	Data server [yyyy-MM-dd HH:mm:ss.fff]
INTEGRATEDOZONE	Double	Ozone accumulated up to the sounding termination [DU] (Dobson Unit)
RESIDUALOZONE	Double	Estimated residual ozone above the termination level [DU] (Dobson Unit)
SENSORTYPE	String	Sensor type code
INTERFACETYPE	String	Ozone interface type (Undefined, OIF411, or OIF92)
SERIALNUMBER	String	OIF serial number
DIAGNOSTIC	Int	OIF411: diagnostic word OIF92: 0
BGCURRENTCORRMETHOD	String	Background current correction method
SMOOTHINGMETHOD	String	OIF411: null OIF92: method for smoothing measured data
CALIBRATIONPRESSURE	Double	Applied calibration pressure [hPa]
BGCURRENT	Double	Sensor background current [uA]
SOLUTIONVOLUME	Double	Cathode solution volume [cm ³]
OZONEPRIORSTART	Double	Ozone at the surface level prior to the launch [DU] (Dobson Unit)
PRIORSTARTMEASDURATION	Double	Surface ozone measurement duration [min]

Raw Ozone Data

Ozone layer data without pressure correction.

Table 22 **RawOzone**

Column Name	Type	Description
SOUNDINGIDPK	String	Unique sounding ID
RADIORXTIMEPK	Double	Radio time [s]
DATASRVTIME	String	Data server [yyyy-MM-dd HH:mm:ss.fff]
PARTIALPRESSURE	Double	Raw (uncorrected) ozone partial pressure [mPa]
INTERMEDIATE	Double	Intermediate data being used in calculation
CURRENT	Double	Current measured by sensor [uA]
BOXTEMPERATURE	Double	Sensor box temperature [K]
VOLTAGE	Double	OIF92: Channel 3 data OIF411: Battery voltage measurement [V]
AUX	Double	OIF411: ozone pump current value [mA] OIF92: channel 4 data
EXTERNALVOLTAGE	Double	OIF411: external voltage measurement [V] OIF92: 0

APPENDIX B

SAFETY INSTRUCTIONS FOR BALLOON OPERATORS

This appendix contains details of safe and proper balloon preparation.

Photocopy these instructions and place the list in clear view in the balloon filling shed and in the sounding compartment.

1. No smoking or naked flame allowed.
2. If possible, avoid wearing clothing made of nylon or other synthetic fibers to prevent a build-up of static charges. Do not wear shoes with rubber soles.
3. Wear protective glasses.
4. Regularly check that the gas tube fits securely to the gas cylinder or generator nozzle and to the balloon inflation nozzle.
5. Take care to prevent a gas leak in the shed when interrupting inflation to replace a gas cylinder.
6. Never use a repaired balloon.
7. Should a leak develop in the balloon during inflation, do not let gas escape from the balloon inside the shed if possible. Instead, release the defective balloon without load. It is not advisable to deflate the balloon, even outside the shed.
8. Do not touch the balloon with bare hands except when holding it by the neck. Wear soft cotton gloves.

9. Ensure that there are no pointed objects in the shed. Nails, hooks, hinges, padlocks, etc., are dangerous as they might scratch the inflated balloon. The balloon film is only 0.05 ... 0.1 mm thick upon launch; the slightest scratch could cause the balloon to burst prematurely.
10. Keep the doors of the shed shut while inflating the balloon on a windy day. However, ensure that the shed is properly ventilated.
11. No unauthorized person shall be allowed admittance to the shed while the hydrogen generator is in operation or balloon inflation is going on.
12. Ensure that all tools and other implements not essential for balloon inflation have been removed from the shed.
13. Do not take any electrical devices (cell phone etc.) to the balloon filling shed or close to the balloon inflated with hydrogen. Safe distance when outdoors is typically 1.5 meters.
14. Always keep the radiosonde at least 50 cm below the level of the gas nozzle and the inflated balloon, and at least 1.5 meters away from the gas cylinder/hydrogen generator, connectors, and tubing. Avoid taking the radiosonde inside the balloon filling shed, if possible.
15. Follow all regulations concerning hydrogen safety.

WARNING

New operator! Carefully study the instructions for using the hydrogen generator and for the correct method of inflation.

APPENDIX C

CHECKLIST FOR EQUIPMENT AND SUPPLIES FOR FLIGHT PREPARATIONS

This appendix contains the checklist for the equipment and supplies needed in the sounding preparations. You can mark the items in the Checked column.

Table 23 Checklist for Equipment

Equipment	Checked
Ozone sensor with styrofoam flight box and motor battery	
Radiosonde RS41	
Ozone Interface Board OIF411	
Balloon (plastic or rubber)	
5 meters of string (strength about 300 to 500 N), an unwinder and a detainer	
Parachute, 200-inch (500 cm) circumference (recommended)	
Short-circuit cable for the ozone sensor (optional)	
Ozone sensor interface - radiosonde extender test cable (optional)	
Bottle for the sensor cathode solution prepared according to the instructions	
Bottle for the sensor anode solution prepared according to the instructions	
Bottle for distilled H ₂ O	

Table 23 Checklist for Equipment (Continued)

Equipment	Checked
Syringe, 3 ml volume (equipped with Teflon tube), for use with the sensor cathode solution	
Syringe, 3 ml volume, for use with the sensor anode solution	
Roll of firm tape, 2 inches (5 cm) wide	
Apparatus for measuring ozone sensor air flow rate	
Ozonesonde power supply for pump motor rated at 12 to 13 VDC, 300 mA	
SPC Ozonizer/Test Unit Model TSC-1 with adapter cables or equivalent from other manufacturers	
Ozone destruction filter or purified, ozone-free gas	
Thermometer graduated in degrees centigrade	
Hand-held pressure/vacuum gauge for pump tests	
Small strips of No. 600A sandpaper for grasping Teflon tubing	
Plastic squirt bottle filled with research-grade methanol	
Methanol and acetone for cleaning	
Pair of lint-free gloves for laboratory work (made of artificial fabric or plastic, disposable)	

APPENDIX D

PERFORMANCE REVIEW LITERATURE

This appendix provides a list of relevant performance review literature.

Table 24 Performance Review Literature

Name	Details
Attmannspacher, W. and H.U. Dütsch	International Ozone Sonde Intercomparison at Observatory Hohenpeissenberg. Bericht des Deutschen Wetterdienstes, No. 120, 1970, 85 pp.
Attmannspacher, W and H.U. Dütsch	2nd. International Ozone Sonde Intercomparison at Observatory Hohenpeissenberg. Bericht des Deutschen Wetterdienstes, No. 157, 1981, 65 pp.
De Backer, Hugo, D. De Muer and G. De Sadelaer	Comparison of ozone profiles obtained with Brewer-Mast and Z-ECC sensors during simultaneous ascents. J. Geoph. Res., vol. 103, D16, 19641 - 19648. Johnson, B.J. , S.J. Oltmans, H. Voemel, H.G.J Smit, T. Deshler, and C. Kroeger (2002), ECC ozonesonde pump efficiency measurements and tests on the sensitivity to ozone of buffered and unbuffered ECC sensor cathode solutions. J. Geophys. Res., 107, D19 doi: 10.1029/2001JD000557. 1998.
Beekman, M. and G. Ancellet, D. Martin, C. Abonnel, G. Duverneuil and F. Eideliman, P. Bessemoulin, N. Fritz and E. Gizard	Intercomparison of tropospheric ozone profiles obtained by electrochemical sondes, a ground based lidar and an airborne UV-photometer Atmospheric Environment Vol. 29, No. 9, pp. 1027-1042, 1995.
Brewer, A.W. and J.R. Milford	The Oxford-Kew Ozonesonde, Proc. Roy. Soc A, 256, 470, 1960.
Deshler, T., Mercer, H.G.J Smit, R. Stubi, G. Levrat, B.J. Johnson, S.J. Oltmans, R. Kivi, J. Davies, A.M. Thompson, J. Witte, F.J. Schmidlin, G. Brothers, T. Sasaki	Atmospheric comparison of electrochemical cell ozonesondes from different manufacturers, and with different cathode solution strenghts: The Balloon Experiment on Standards for Ozonesondes, J. Geophys. Res., 113, D04307, doi: 10.1029/2007JD008975. Komhyr, W. D. (1969), Electrochemical concentration cells for gas analysis, Ann. Geoph., 25, 203 - 210. 2008.

Table 24 Performance Review Literature (Continued)

Name	Details
Godson, W.L.	The representation and analysis of vertical distributions of ozone, Quarterly Journal of the Meteorological Society, Vol. 88, No. 377, July 1962.
Hoegger, B.A. & all	Contribution of Switzerland to International Ozonesonde Intercomparisons. Proceedings of GAW-CH Conference Zurich, 14-15 October 1998. Swiss Agency for the Environment, Forests and Landscape (SAEFL), Environmental documentation No.110 Air, pp 43-47.
Johnson, Bryan J., Samuel J. Oltmans, H. Vomel, H.G.J. Smit, T. Deshler., and C. Kroger	Electrochemical concentration cell (ECC) ozonesonde pump efficiency measurements and tests on the sensitivity to ozone of buffered and unbuffered ECC sensor cathode solutions. J. Geophys. Res., 107 (D19), 4394, doi:1029/2001JD000557, 2002.
Kerr, J.B. & all	The 1991 WMO international ozonesonde intercomparison at Vanscoy, Canada. Atmosphere Ocean, Vol XXXII, No 4 pp 685-716, December 1994.
Kley, D., H.G.J. Smit, H. Vömel, H. Grassl, V. Ramanathan, P.J. Crutzen, S. Williams, J. Meywerk, S.J. Oltmans	Tropospheric water-vapour and ozone cross-sections in a zonal plane over the equatorial Pacific Ocean, Q.J.R. Meteorol. Soc. (1997), 123, pp. 2009-2040.
Komhyr, W.D.	Operations Handbook - Ozone Measurement to 40-km Altitude with 4A Electrochemical Concentration Cell (ECC) Ozonesondes (used with 1680-MHz radiosondes), NOAA Technical Memorandum ERL ARL-149,1986.
Komhyr, W.D., J.A. Lathrop, D.P. Opperman, R.A. Barns, and G.B. Brothers	ECC Ozonesonde performance evaluation during STOIC 1989, J. Geophys. Res., 100 9231-9244, 1995.
Komhyr, W.D.	Electrochemical Concentration Cell for Gas Analysis Ann. Geophys., t. 25, fasc. 1, 1969, pp. 203-210.
Schenkel, A., and B. Broder	Interference of some trace gases with ozone measurements by the KI method, Atmospheric Environment, 16, 2187-2190. 1982.
Schmidlin, F.J., B.A. Hoegger & all	Sondex96: A Field Experiment Conducted by NASA and SMI at Payerne, Switzerland. WMO Instruments and Observing Methods Report No 70, WMO Technical Conference on Meteorological and Methods of Observation (TECO-98), Casablanca Morocco, 13-15 May 1998, (WMO/TD No. 877), pp 193-196.
Smit, H.G.J and ASOPOS panel	Quality assurance and quality control for ozonesonde measurements in GAW, WMO Global Atmosphere Watch Report series, No. 121, World Meteorological Organization, Geneva, 2013.
Smit, H.G.J.	Ozonesondes, in Encyclopedia of Atmospheric Sciences, edited by J. Holton, J. Pyle, and J. Curry, pp. 1469-1476, Academic Press, London. 2002.

Table 24 Performance Review Literature (Continued)

Name	Details
Smit, H.G.J., W. Straeter, B. Johnson, S. Oltmans, J. Davies, D.W. Tarasick, B. Hoegger, R. Stubi, F. Schmidlin, T. Northam, A. Thompson, J. Witte, I. Boyd, F. Posny	Assessment of the performance of ECC-ozonesondes under quasi-flight conditions in the environmental simulation chamber: Insights from the Jülich Ozone Sonde Intercomparison Experiment (JOSIE), J. Geophys. Res., 112, D19306, doi:10.1029/2006JD007308. 2007
Smit, H.G.J. and D.Kley	Jülich Ozone Sonde Intercomparison Experiment (JOSIE) ; WMO Global Atmosphere Watch report series No. 130 (Technical document No.926) WMO, Geneva, 1998.
Smit, H.G.J. & all	The 1996 WMO International intercomparison of ozonesondes under quasi flight conditions in the environmental simulation chamber at Jülich, Proceedings XVIII Quadrennial Ozone Symposium, Eds. R. Bojkov, and G. Visconti, L'Aquila, Italy, Sept. 1996.
Smit, H.G.J. & all	The 1996-1999 Evaluation of Performance of ECC- Sondes Under Quasi-Flight Conditions in the Environmental Simulation Chamber, Proceedings of Quadrennial Ozone Symposium 2000, Sapporo, Japan, July 2000.
	SPARC-IOC-GAW Assessment of Trends in the Vertical Distribution of Ozone (1998), SPARC Report No.1, WMO Global Ozone Research and Monitoring Project Report No. 43, World Meteorological Organization, Geneva. Note: In this report performance investigations made before 1996 have been intensively evaluated by the SPARC-IOC-GAW assessment panel
Stübi R., G. Levrat, B. Hoegger, P. Viatte, J. Staehelin, F. J. Schmidlin	In-flight comparison of Brewer-Mast and electrochemical concentration cell ozonesondes, J. Geophys. Res., 113, D13302, doi:10.1029/2007JD009091. 2008.
WMO	Third WMO intercomparison of the ozonesondes used by the Global ozone observing System, Vanscoy Canada 13-24 May 1991, WMO/ Global Atmosphere Watch/WMO Global Ozone Research and Monitoring Project, Report No 27.

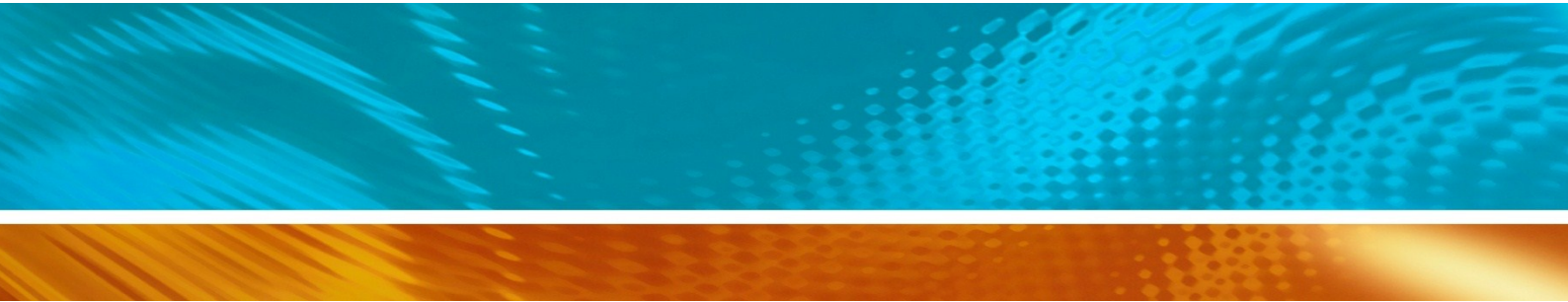

www.vaisala.com

